

General Description

The MDWS12C013PERH uses advanced Magnachip's SSCFET® II Technology, which provides high performance in on-state resistance and excellent reliability. Excellent low $R_{SS(ON)}$, low gate charge operation and operation for Battery Application.

Features

- $V_{SS} = 12V$
- Source-Source ON Resistance;
 - $R_{SS(ON)} < 1.15m\Omega$ @ $V_{GS} = 4.5V$
 - $R_{SS(ON)} < 1.20m\Omega$ @ $V_{GS} = 3.8V$
 - $R_{SS(ON)} < 1.65m\Omega$ @ $V_{GS} = 3.1V$
 - $R_{SS(ON)} < 2.80m\Omega$ @ $V_{GS} = 2.5V$

Applications

- Portable Battery Protection

Bottom View

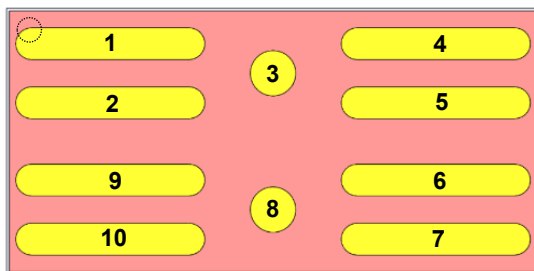

2.98mm x 1.49mm WLCSP

1, 2, 4, 5. Source1 (FET1) 3. Gate1 (FET1)
 6, 7, 9, 10. Source2 (FET2) 8. Gate2 (FET2)

Equivalent Circuit

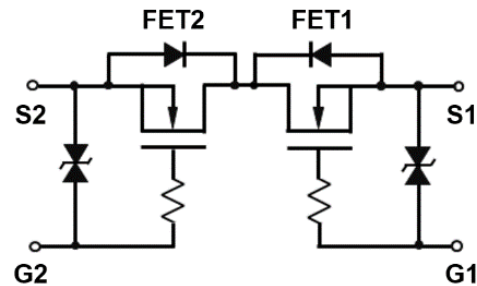

Absolute Maximum Ratings

Characteristics		Symbol	Rating	Units
Source-Source Voltage		V_{SSS}	12	V
Gate-Source Voltage		V_{GSS}	±8	V
Source Current	DC *1	I_S	33	A
	Pulse	I_{SP}	132	A
Total Power Dissipation	DC *1	P_D	2.0	W
Channel Temperature		T_{ch}	-55~150	°C
Junction and Storage Temperature Range		T_J, T_{stg}	-55~150	°C

Thermal Characteristics

Characteristics	Symbol	Rating	Unit
Thermal Resistance *1	$R_{\theta JA}$	63.4	°C/W

Ordering Information

Part Number	Temp. Range	Package	Packing	RoHS Status
MDWS12C013PERH	-55~150 °C	WLCSP	Tape and Reel	Halogen Free

Electrical Characteristics (T_A =25°C unless otherwise noted)

Characteristics	Symbol	Test Condition	Min	Typ	Max	Units
Static Characteristics						
Source-Source Breakdown Voltage	BV _{SSS}	I _S = 250μA, V _{GS} = 0V	12	-	-	V
Gate Threshold Voltage	V _{GS(th)}	V _{SS} = V _{GS} , I _S = 250μA	0.4	0.85	1.3	
Cut-Off Current	I _{SSS}	V _{SS} = 12V, V _{GS} = 0V	-	-	1	μA
Gate Leakage Current	I _{GSS1}	V _{GS} = ±8V, V _{SS} = 0V	-	-	10	μA
	I _{GSS2}	V _{GS} = ±5V, V _{SS} = 0V	-	-	1	
Source-Source Resistance	R _{SS(ON)}	V _{GS} = 4.5V, I _S = 5.0A	-	0.85	1.15	mΩ
		V _{GS} = 3.8V, I _S = 5.0A	-	0.90	1.20	
		V _{GS} = 3.1V, I _S = 5.0A	-	1.10	1.65	
		V _{GS} = 2.5V, I _S = 5.0A	-	1.40	2.80	
Dynamic Characteristics *1						
Total Gate Charge	Q _g	V _{DD} = 6V, I _S = 5.0A, V _{GS} = 3.8V	-	32.8	-	nC
Gate-Source Charge	Q _{gs}		-	6.0	-	
Gate-Drain Charge	Q _{gd}		-	11.0	-	
Input Capacitance	C _{iSS}	V _{SS} = 6V, V _{GS} = 0V, f = 50kHz	-	4304	-	pF
Reverse Transfer Capacitance	C _{rSS}		-	810	-	
Output Capacitance	C _{oss}		-	927	-	
Turn-On Delay Time	t _{d(on)}	V _{GS} = 3.8V, V _{DD} = 6V, I _S = 5.0A, R _{GEN} = 3Ω	-	0.01	-	μS
Rise Time	t _r		-	0.05	-	
Turn-Off Delay Time	t _{d(off)}		-	16.7	-	
Fall Time	t _f		-	29.8	-	
Drain-Source Body Diode Characteristics						
Source-Source Diode Forward Voltage	V _{F(S-S)}	I _F = 5A, V _{GS} = 0V	-	0.7	1.2	V

Note *1. Test on PCB board (60.0mm x 15.0mm x 1.0t)

Characteristic Graph*1

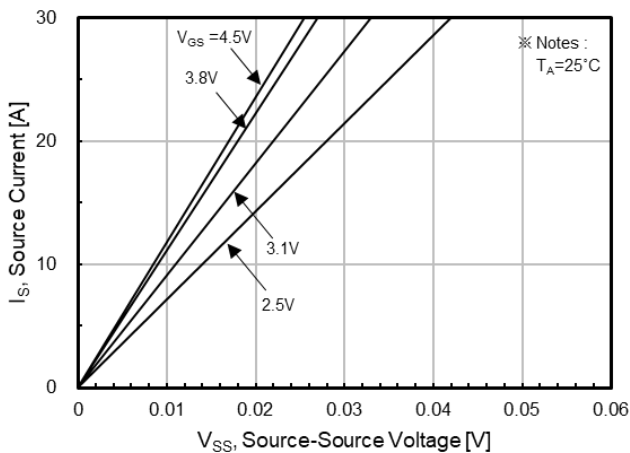

Fig.1 On-Region Characteristics

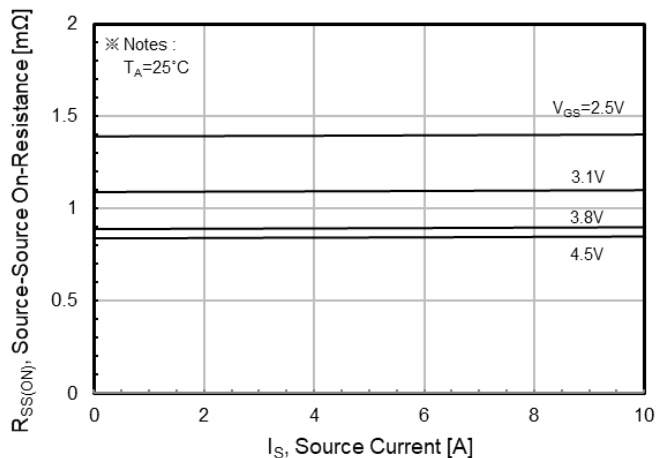

Fig.2 On-Resistance Variation with Drain Current and Gate Voltage

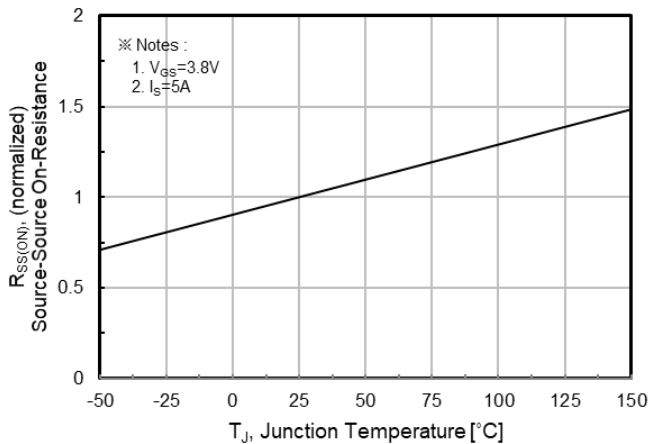

Fig.3 On-Resistance Variation with Temperature

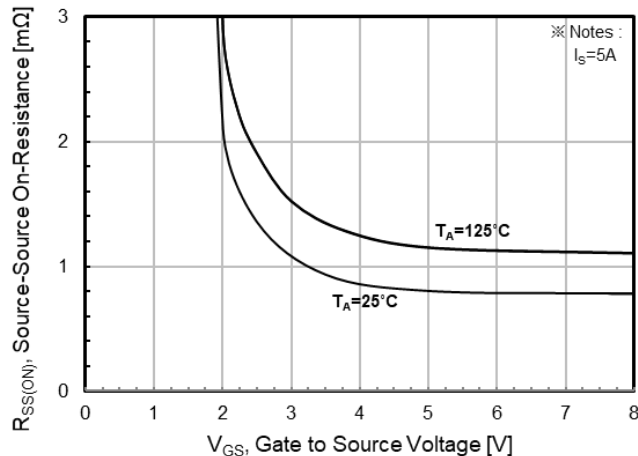

Fig.4 On-Resistance Variation with Gate to Source Voltage

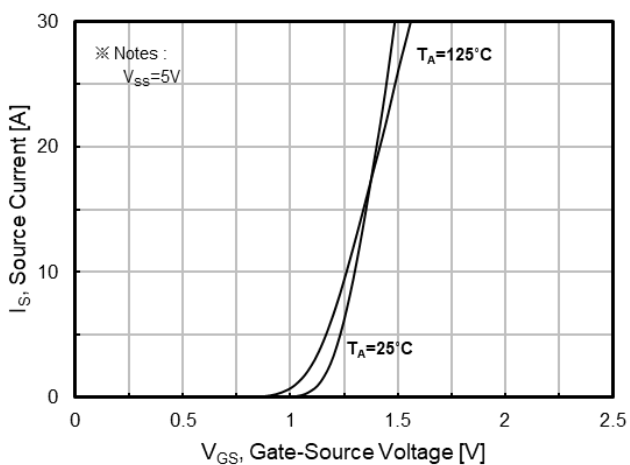

Fig.5 Transfer Characteristics

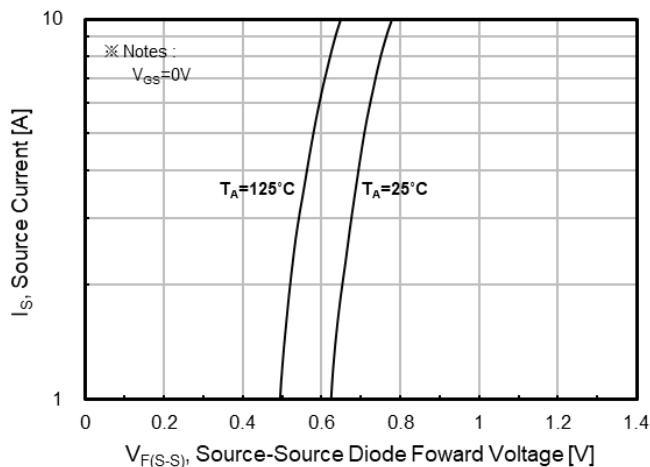

Fig.6 Forward Source to Source Characteristics

Characteristic Graph*1

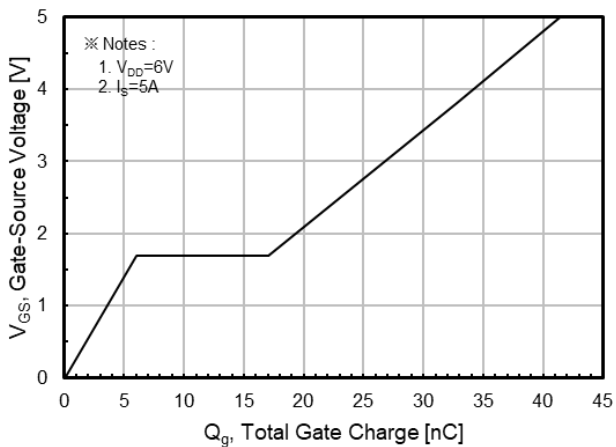

Fig.7 Gate Charge Characteristics

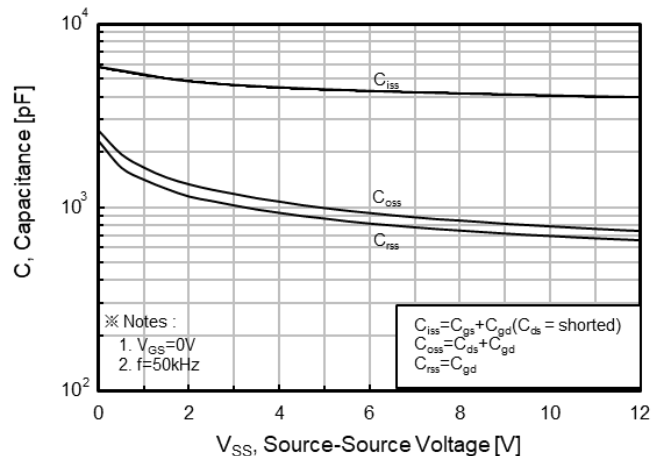

Fig.8 Capacitance Characteristics

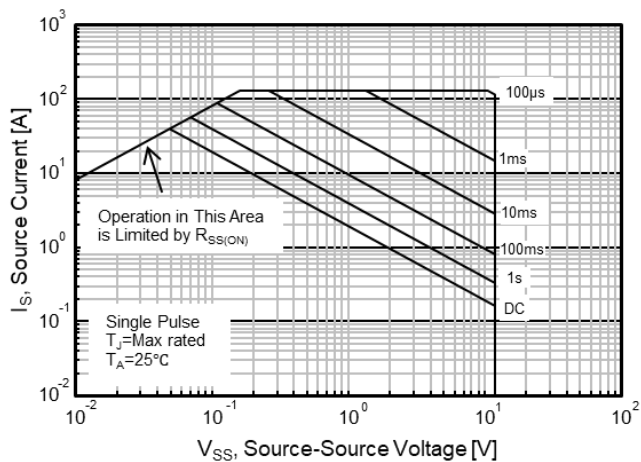

Fig.9 Maximum Safe Operating Area

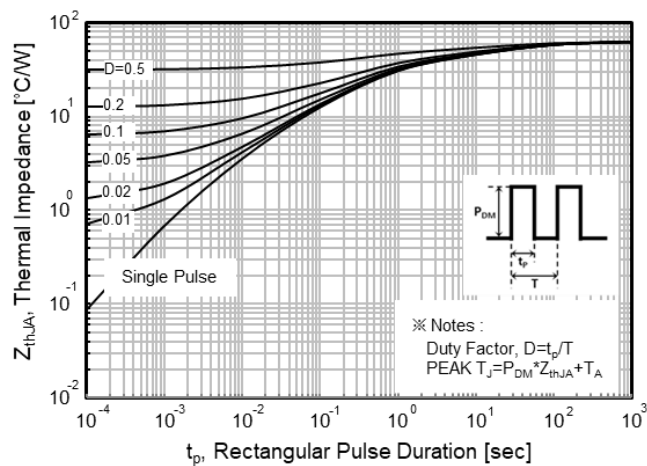
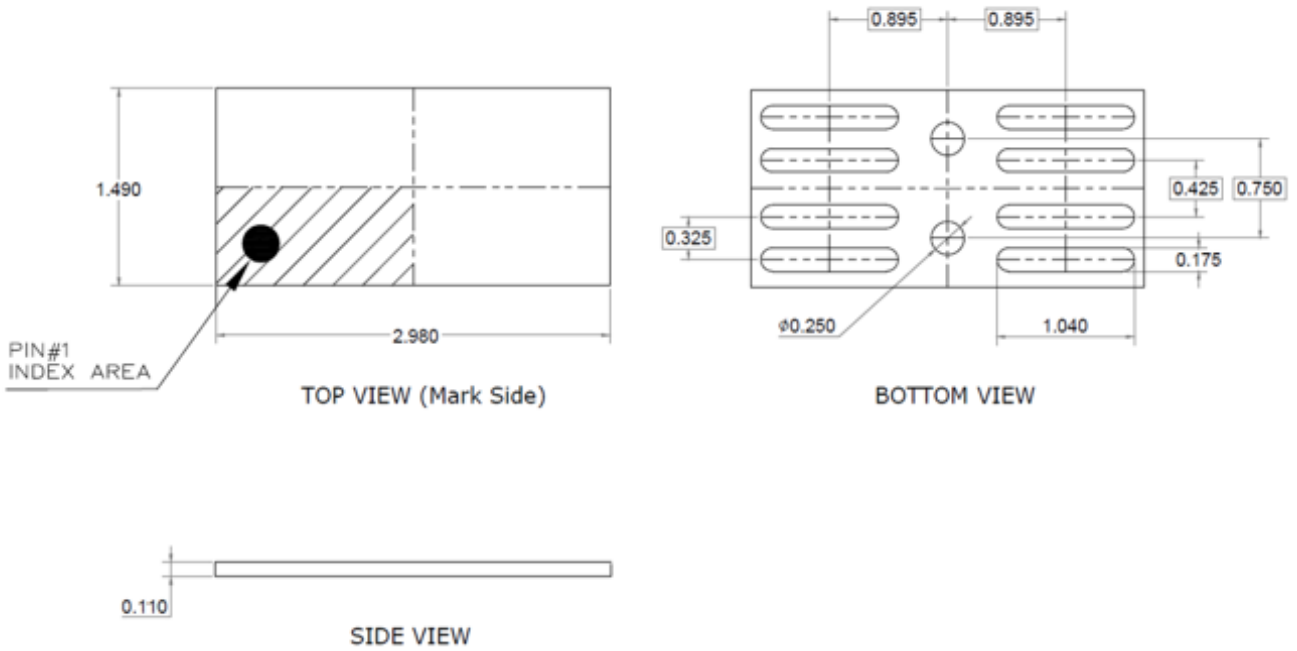

Fig.10 Transient Thermal Response Curve

Package Outline



NOTES:

1. ALL DIMENSIONS ARE IN MILLIMETERS.
2. GENERAL TOLERANCE : ± 0.03 mm
3. PACKAGE BODY SIZES EXCLUDE FLASH & BURRS

DISCLAIMER:

The Products are not designed for use in hostile environments, including, without limitation, aircraft, nuclear power generation, medical appliances, and devices or systems in which malfunction of any Product can reasonably be expected to result in a personal injury. Seller's customers using or selling Seller's products for use in such applications do so at their own risk and agree to fully defend and indemnify Seller.

Magnachip reserves the right to change the specifications and circuitry without notice at any time. Magnachip does not consider responsibility for use of any circuitry other than circuitry entirely included in a Magnachip product.  Magnachip is a registered trademark of Magnachip Semiconductor Ltd.