

General Description

Hybrid Discrete – IGBT co-packed with SiC diode.
 This IGBT is produced using advanced Magnachip’s Field Stop Trench IGBT Technology, which provides low $V_{CE(sat)}$, low switching loss performance and excellent quality.

Features

- $V_{CE(sat)} = 1.65V @ I_C = 75A$
- Low Switching Loss
- Anti-parallel SiC diode
- Maximum Junction Temperature 175°C

Applications

- PV Inverter
- ESS

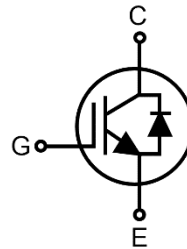

Package outline and symbol

- G : Gate
- C : Collector
- E : Emitter

Absolute Maximum Ratings

Characteristics		Symbol	Rating	Unit
Collector-emitter voltage		V_{CES}	650	V
Gate-emitter voltage		V_{GE}	±20	V
DC collector current ¹⁾	$T_C=25^\circ C$	I_C	80	A
	$T_C=100^\circ C$		75	A
Pulsed collector current, t_p limited by T_{vjmax}		I_{Cpuls}	225	A
Diode forward current ¹⁾	$T_C=25^\circ C$	I_F	57.0	A
	$T_C=100^\circ C$		36.8	A
Diode pulsed current, t_p limited by T_{vjmax}		I_{Fpuls}	135	A
Total power dissipation	$T_C=25^\circ C$	P_{tot}	319	W
	$T_C=100^\circ C$		159	W
Operating Junction temperature range		T_{vj}	-40~175	°C
Storage temperature range		T_{stg}	-55~150	°C

Note 1) Current is limited by junction temperature & bondwires.

Thermal Characteristics

Characteristics	Symbol	Rating	Unit
Thermal resistance junction-to-ambient	$R_{th(j-a)}$	40	°C/W
Thermal resistance junction-to-case for IGBT	$R_{th(j-c)}$	0.47	
Thermal resistance junction-to-case for Diode	$R_{th(j-c)}$	0.77	

Ordering Information

Part Number	Marking	Temp. Range	Package	Packing	RoHS Status
MBQ75T65S6MSTH	75T65S6MS	-55~150°C	TO-247	Tube	Compliant

Electrical Characteristics ($T_{vj} = 25^\circ\text{C}$ unless otherwise specified)

Parameter	Symbol	Conditions	Min	Typ	Max	Unit	
Static Characteristics							
Collector-emitter breakdown voltage	BV_{CES}	$I_C = 0.1\text{mA}, V_{GE} = 0\text{V}$	650	-	-	V	
Collector-emitter saturation voltage	$V_{CE(sat)}$	$I_C = 75\text{A}, V_{GE} = 15\text{V}$	$T_{vj} = 25^\circ\text{C}$	-	1.65	2.10	V
			$T_{vj} = 175^\circ\text{C}$	-	2.15	-	
Diode forward voltage	V_F	$V_{GE} = 0\text{V}, I_F = 20\text{A}$	$T_{vj} = 25^\circ\text{C}$	-	1.40	1.70	V
			$T_{vj} = 175^\circ\text{C}$	-	1.65	-	
		$I_F = 30\text{A}, T_{vj} = 25^\circ\text{C}$	-	1.60	-		
Gate-emitter threshold voltage	$V_{GE(th)}$	$V_{CE} = V_{GE}, I_C = 1\text{mA}$	4.0	5.0	6.0	V	
Zero gate voltage collector current	I_{CES}	$V_{CE} = 650\text{V}, V_{GE} = 0\text{V}$	-	-	200	μA	
Gate-emitter leakage current	I_{GES}	$V_{GE} = 20\text{V}, V_{CE} = 0\text{V}$	-	-	± 250	nA	

Dynamic Characteristics

Total gate charge	Q_G	$V_{CE} = 520\text{V}, I_C = 75\text{A}, V_{GE} = 15\text{V}$	-	112	-	nC
Gate-emitter charge	Q_{GE}		-	22	-	
Gate-collector charge	Q_{GC}		-	41	-	
Input capacitance	C_{ies}	$V_{CE} = 25\text{V}, V_{GE} = 0\text{V}, f = 100\text{kHz}$	-	3146	-	pF
Output capacitance	C_{oes}		-	360	-	
Reverse transfer capacitance	C_{res}		-	26	-	

Switching Characteristics

Turn-on delay time	$t_{d(on)}$	$V_{GE} = 0/15\text{V}, V_{CC} = 400\text{V}, I_C = 75\text{A}, R_G = 10\Omega,$ Inductive Load, $T_{vj} = 25^\circ\text{C}$	-	75	-	ns
Rise time	t_r		-	64.6	-	
Turn-off delay time	$t_{d(off)}$		-	184.6	-	
Fall time	t_f		-	164.6	-	
Turn-on switching energy	E_{on}		-	2.2	-	
Turn-off switching energy	E_{off}	-	2.7	-		
Total switching energy	E_{ts}	-	4.9	-		
Turn-on delay time	$t_{d(on)}$	$V_{GE} = 0/15\text{V}, V_{CC} = 400\text{V}, I_C = 75\text{A}, R_G = 10\Omega,$ Inductive Load, $T_{vj} = 175^\circ\text{C}$	-	63.2	-	ns
Rise time	t_r		-	146.0	-	
Turn-off delay time	$t_{d(off)}$		-	174.6	-	
Fall time	t_f		-	166.8	-	
Turn-on switching energy	E_{on}		-	2.5	-	
Turn-off switching energy	E_{off}	-	2.8	-		
Total switching energy	E_{ts}	-	5.3	-		

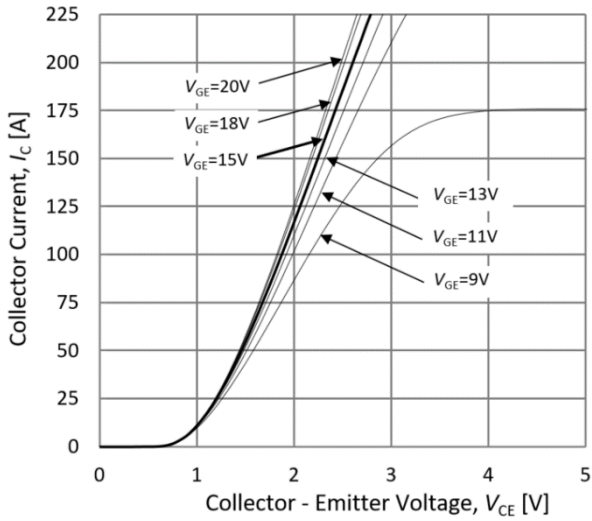

Fig.1. Typical output characteristics ($T_{vj}=25^{\circ}\text{C}$)

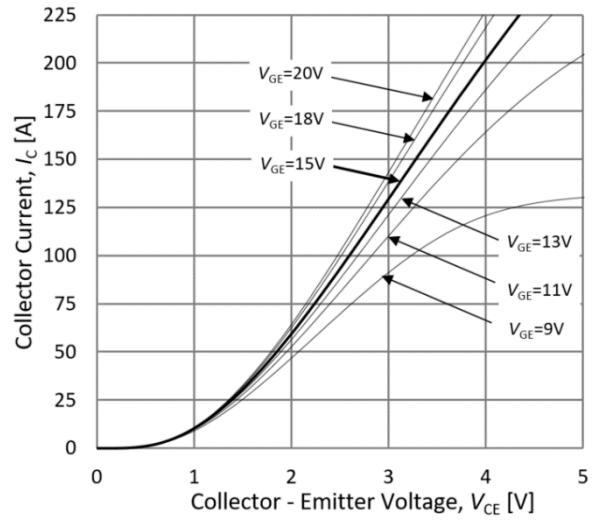

Fig.2. Typical output characteristics ($T_{vj}=175^{\circ}\text{C}$)

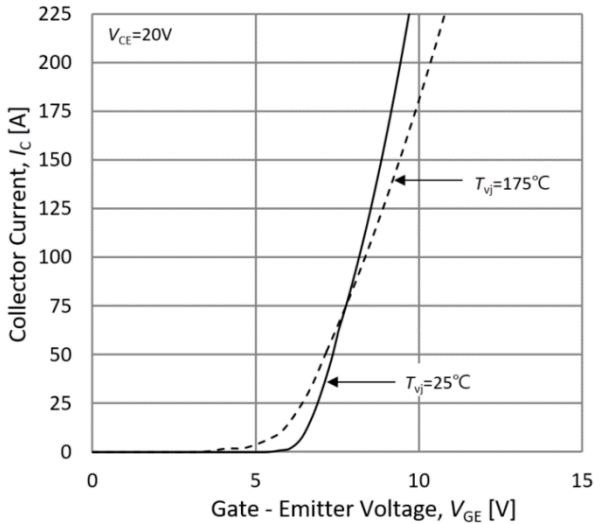

Fig.3. Typical transfer characteristics

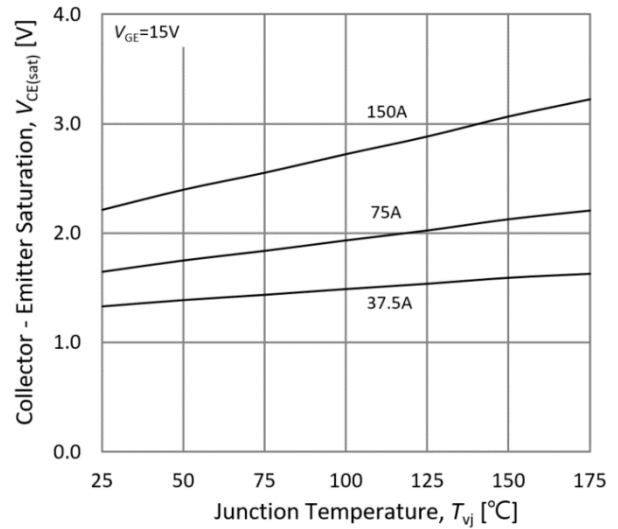

Fig.4. Typical collector-emitter saturation voltage-junction temperature

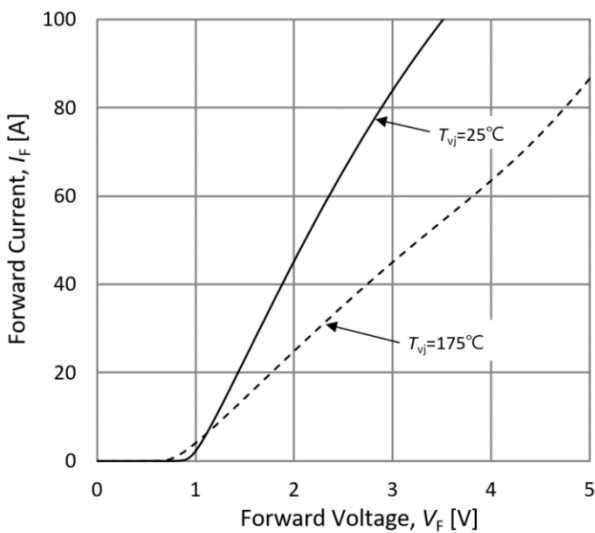

Fig.5. Diode forward characteristics

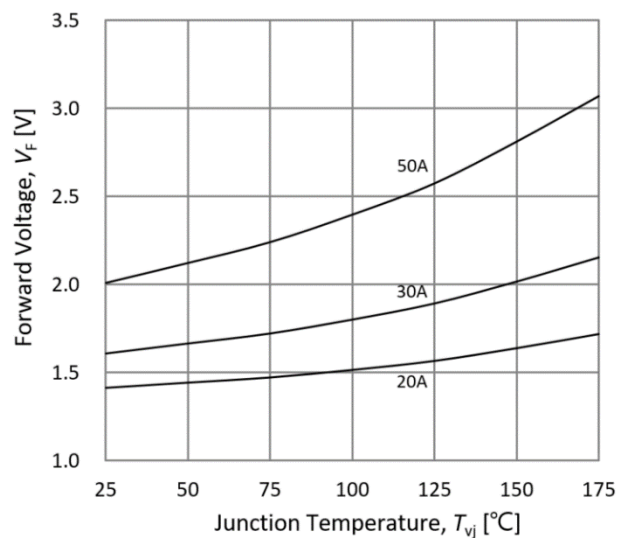

Fig.6. Diode forward voltage-junction temperature

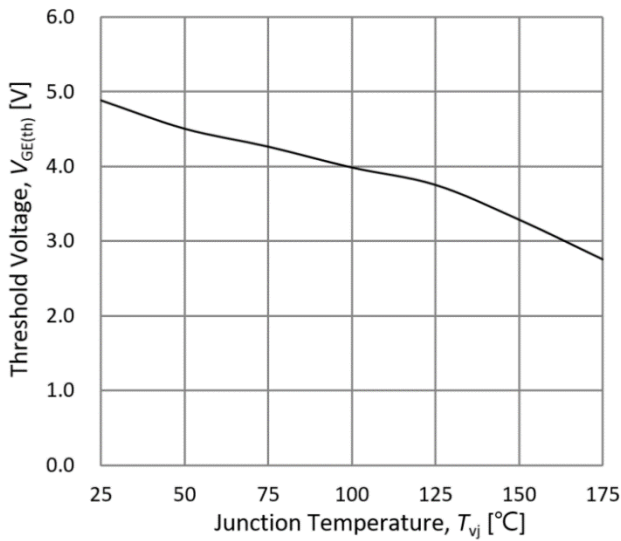

Fig.7. Threshold voltage-junction temperature

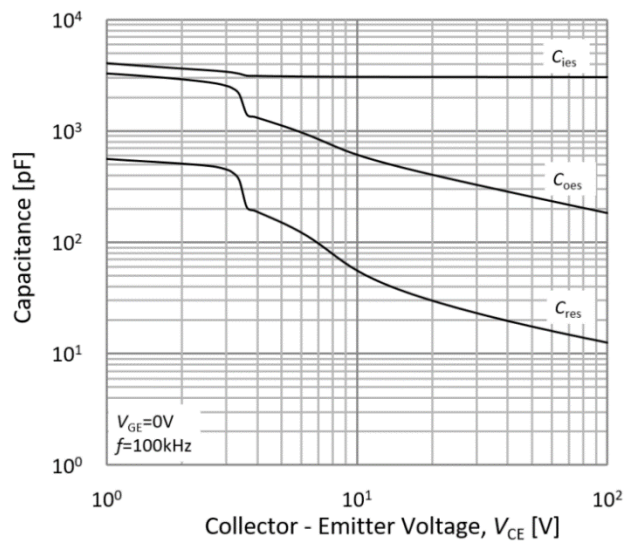

Fig.8. Typical capacitance

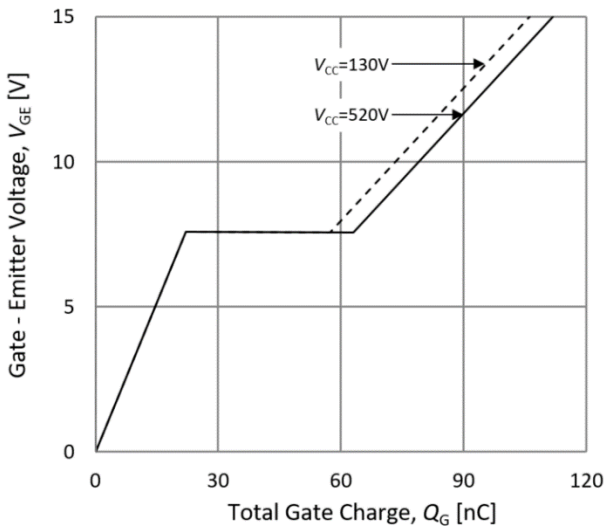

Fig.9. Typical gate charge

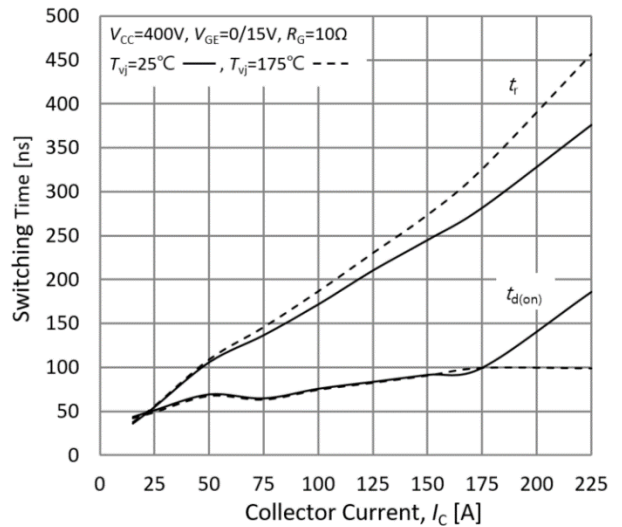

Fig.10. Typical turn on times-collector current

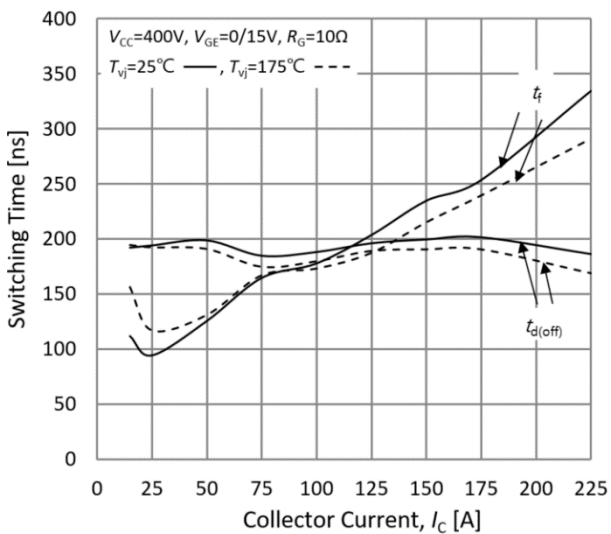

Fig.11. Typical turn off times-collector current

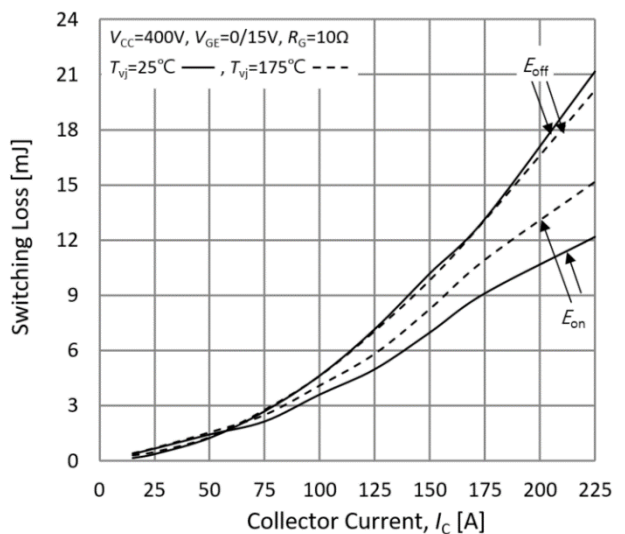

Fig.12. Switching losses-collector current

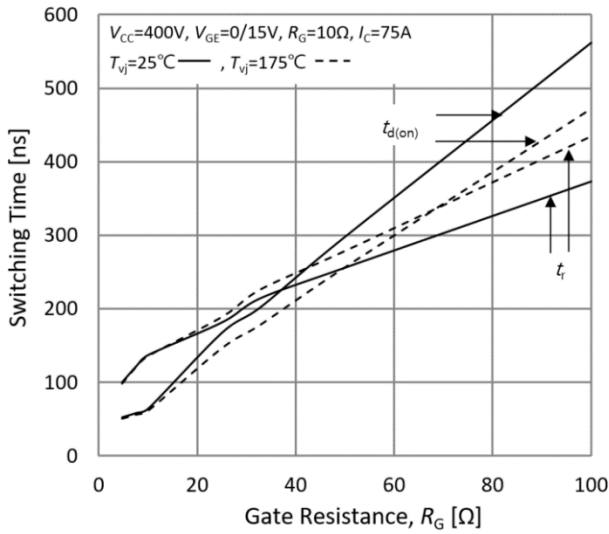

Fig.13. Typical turn on times-gate resistance

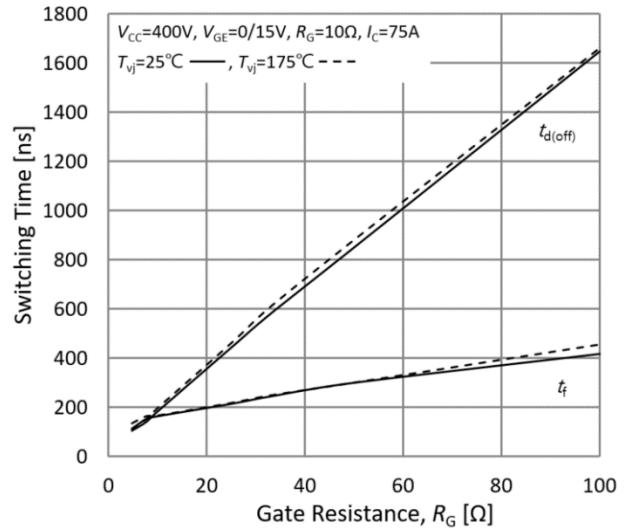

Fig.14. Typical turn off times-gate resistance

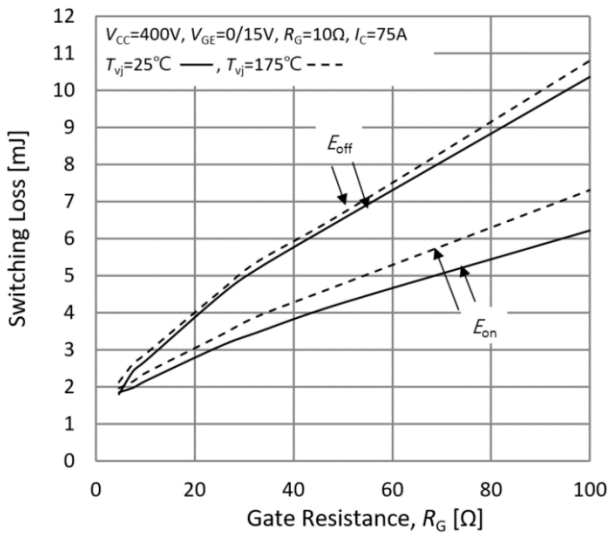

Fig.15. Switching losses-gate resistance

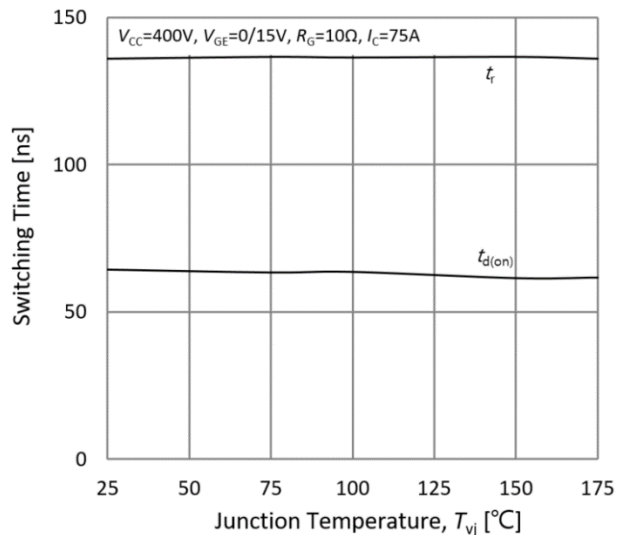

Fig.16. Typical turn on times-junction temperature

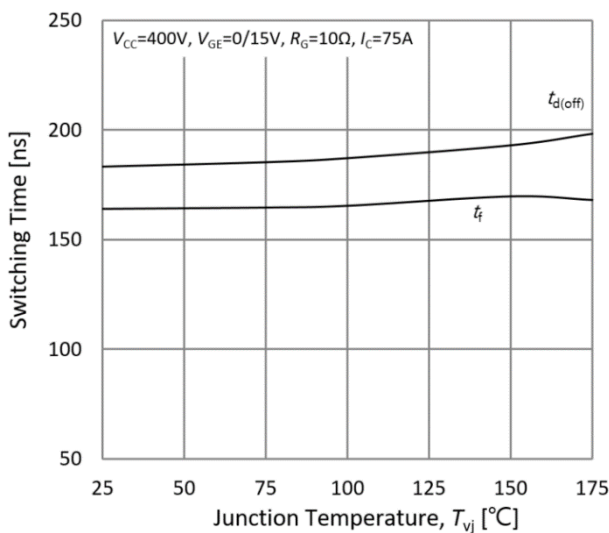

Fig.17. Typical turn off times-junction temperature

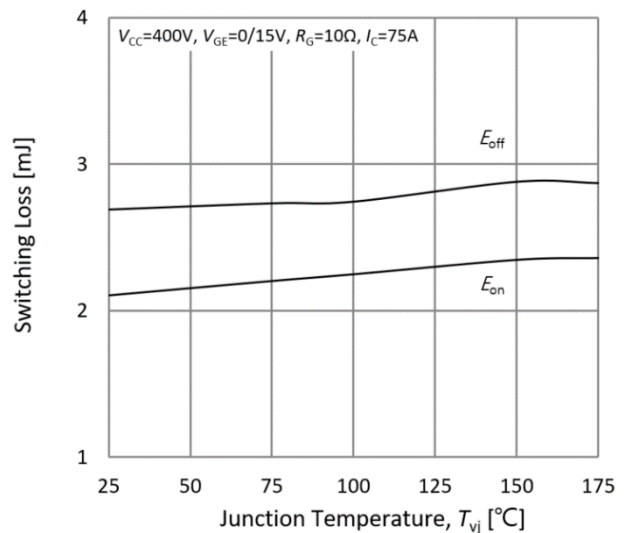

Fig.18. Switching losses-junction temperature

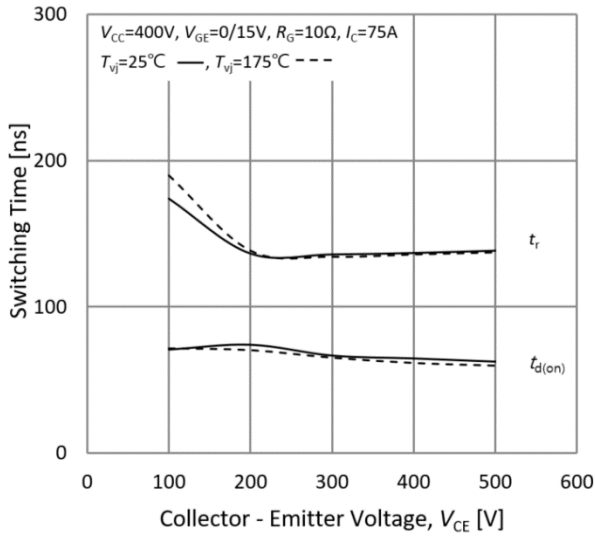

Fig.17. Typical turn on times-collector emitter voltage

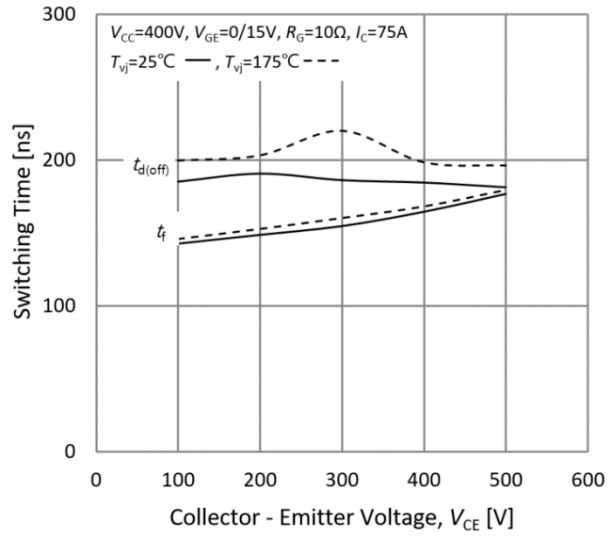

Fig.18. Typical turn off times-collector emitter voltage

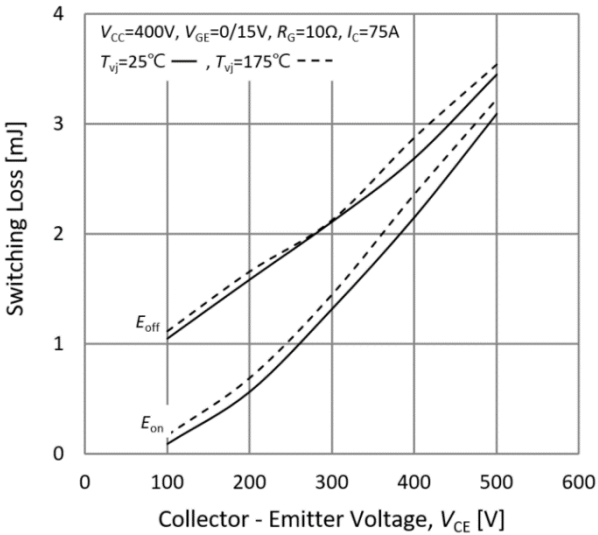

Fig.19. Switching losses-collector emitter voltage

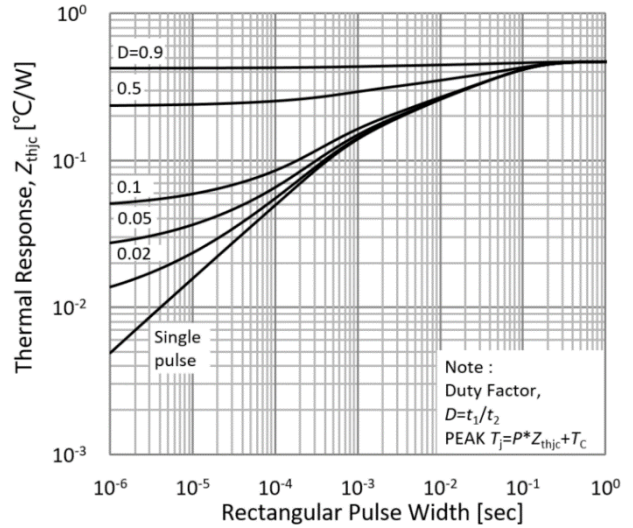

Fig.19. IGBT transient thermal impedance

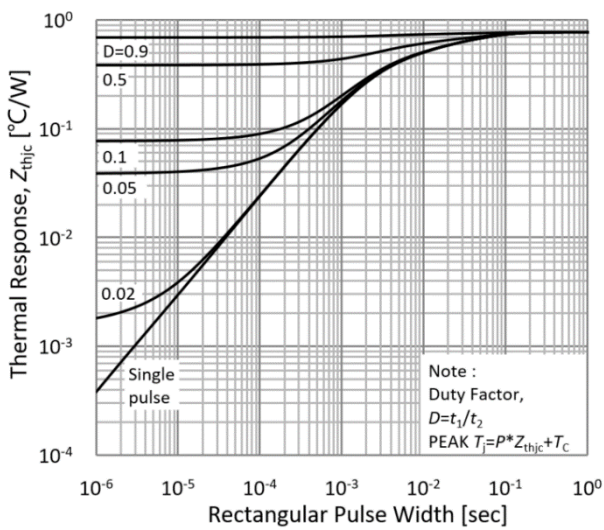

Fig.20. Diode transient thermal impedance

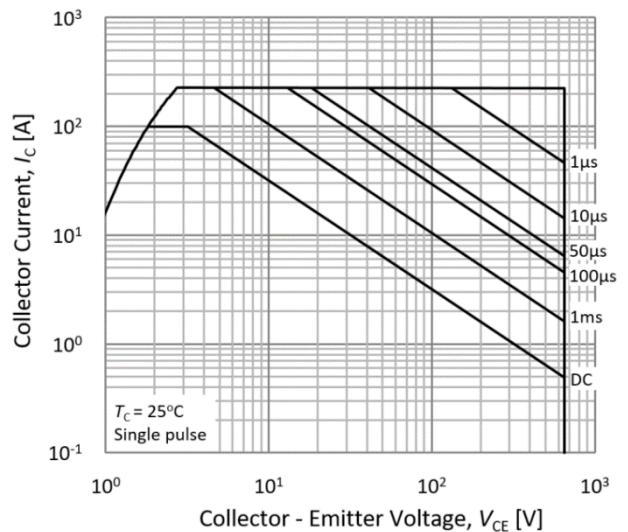

Fig.21. FBSOA

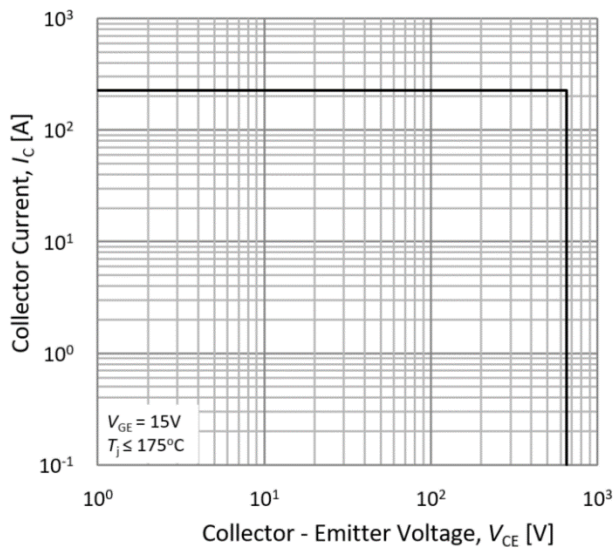
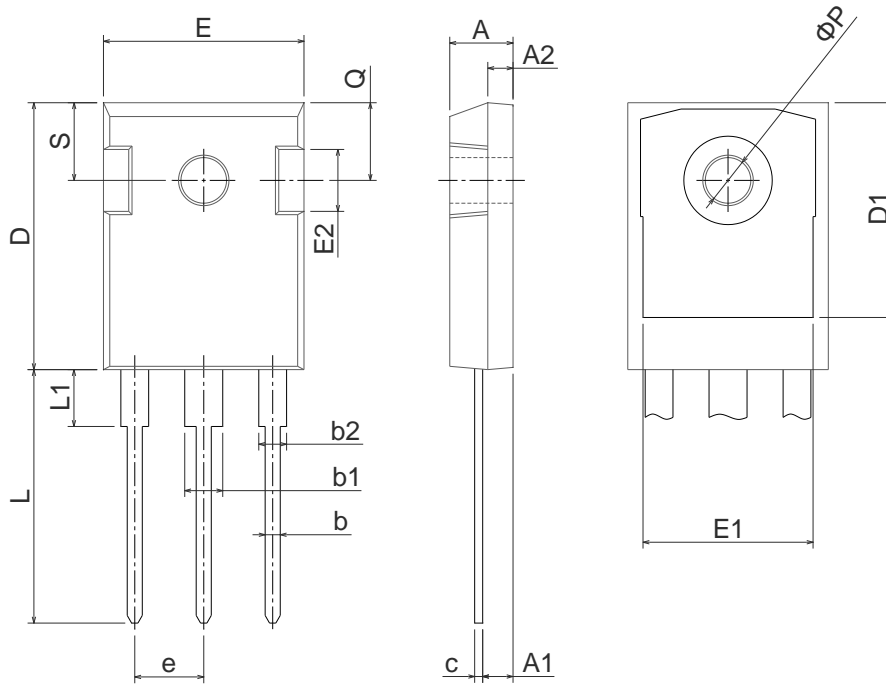

Fig.22. RBSOA

Physical Dimension

TO-247

Dimensions are in millimeters, unless otherwise specified



Dimension	Min(mm)	Max(mm)
A	4.70	5.31
A1	2.20	2.60
A2	1.50	2.49
b	0.99	1.40
b1	2.59	3.43
b2	1.65	2.39
c	0.38	0.89
D	20.30	21.46
D1	13.08	-
E	15.45	16.26
E1	13.06	14.02
E2	4.32	5.49
e	5.45BSC	
L	19.81	20.57
L1	-	4.50
ΦP	3.50	3.70
Q	5.38	6.20
S	6.15BSC	

Note: Package body size, length and width do not include mold flash, protrusions and gate burrs.



DISCLAIMER:

The Products are not designed for use in hostile environments, including, without limitation, aircraft, nuclear power generation, medical appliances, and devices or systems in which malfunction of any Product can reasonably be expected to result in a personal injury. Seller's customers using or selling Seller's products for use in such applications do so at their own risk and agree to fully defend and indemnify Seller.

Magnachip reserves the right to change the specifications and circuitry without notice at any time. Magnachip does not consider responsibility for use of any circuitry other than circuitry entirely included in a Magnachip product.  Magnachip is a registered trademark of Magnachip semiconductor Ltd.