



# MDQ20N116PTFTH

Single N-channel Trench MOSFET 200V 11.6mΩ 95A

## FEATURES

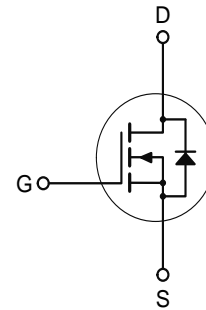
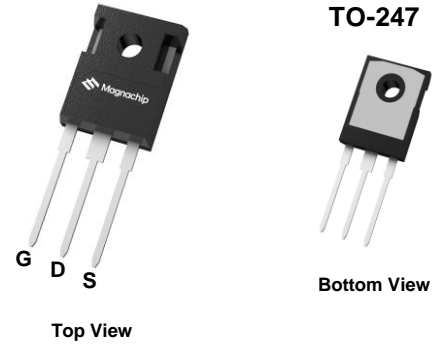
- Trench power MOSFET technology
- N-channel, normal level
- Enhanced avalanche ruggedness
- 100% Avalanche tested
- Maximum 175°C junction temperature
- Improved diode reverse recovery time( $t_{rr}$ ) for increased efficiency

## APPLICATIONS

- DC/DC and AC/DC converters
- Motor drive systems
- Battery powered systems

## KEY PERFORMANCE PARAMETERS

$V_{DS}$	200	V
$R_{DS(on), typ.}$	0.0104	$\Omega$
$I_D$	95	A
$Q_G, typ.$	80	nC
Junction temperature, max.	175	$^{\circ}C$



## ORDERING INFORMATION

Type / Ordering Code	Package	Marking	Packing	RoHS Status
MDQ20N116PTFTH	TO-247	MDQ20N116F	Tube	Halogen Free

<http://www.magnachip.com/>

**MAXIMUM RATINGS**, at  $T_J = 25^\circ\text{C}$ , unless otherwise specified

PARAMETER		SYMBOL	RATING	UNIT
Drain-source Voltage		$V_{DS}$	200	V
Gate-source Voltage		$V_{GS}$	$\pm 20$	V
Drain current	$T_C=25^\circ\text{C}$	$I_D$	95	A
	$T_C=100^\circ\text{C}$		67	A
<sup>1)</sup> Pulsed drain current	$T_C=25^\circ\text{C}$	$I_{DM}$	380	A
Total power dissipation	$T_C=25^\circ\text{C}$	$P_{tot}$	300	W
	$T_C=100^\circ\text{C}$		150	W
<sup>2)</sup> Avalanche energy, single pulse		$E_{AS}$	365	mJ
Operating and storage temperature		$T_j, T_{stg}$	- 55 ~ 175	$^\circ\text{C}$

**THERMAL CHARACTERISTICS**

PARAMETER		SYMBOL	RATING	UNIT
Thermal resistance, junction - case		$R_{\theta JC}$	0.5	$^\circ\text{C}/\text{W}$
<sup>3)</sup> Thermal resistance, junction - ambient		$R_{\theta JA}$	40	$^\circ\text{C}/\text{W}$

ELECTRICAL CHARACTERISTICS (T<sub>J</sub> = 25°C)

## STATIC CHARACTERISTICS

PARAMETER	Symbol	Min.	Typ.	Max.	Unit	Conditions / Note
Drain-source breakdown voltage	V <sub>(BR)DSS</sub>	200	-	-	V	V <sub>GS</sub> =0 V, I <sub>D</sub> =250 μA
Gate threshold voltage	V <sub>GS(th)</sub>	2.25	3.00	3.75	V	V <sub>DS</sub> =V <sub>GS</sub> , I <sub>D</sub> =250 μA
Zero gate voltage drain current	I <sub>DSS</sub>	-	-	10	μA	V <sub>DS</sub> =200 V, V <sub>GS</sub> =0 V
Gate-source leakage current	I <sub>GSS</sub>	-	-	± 100	nA	V <sub>GS</sub> =±20 V, V <sub>DS</sub> =0 V
Drain-source on-state resistance	R <sub>DS(on)</sub>	-	10.4	11.6	mΩ	V <sub>GS</sub> =10 V, I <sub>D</sub> =50 A
<sup>4)</sup> Gate resistance	R <sub>G</sub>	-	2.7	-	Ω	f=1MHz
<sup>4)</sup> Transconductance	g <sub>fs</sub>	-	94	-	S	V <sub>DS</sub> =10 V, I <sub>D</sub> =50 A

<sup>4)</sup> DYNAMIC CHARACTERISTICS

PARAMETER	Symbol	Min.	Typ.	Max.	Unit	Conditions / Note
Input capacitance	C <sub>iss</sub>	-	6951	-	pF	V <sub>GS</sub> =0 V, V <sub>DS</sub> =100 V, f=1 MHz
Output capacitance	C <sub>oss</sub>	-	428	-	pF	
Reverse transfer capacitance	C <sub>rss</sub>	-	12	-	pF	
Turn-on delay time	t <sub>d(on)</sub>	-	30	-	ns	V <sub>DD</sub> =100 V, V <sub>GS</sub> =10 V, I <sub>D</sub> =50 A, R <sub>G,ext</sub> =3Ω
Rise time	t <sub>r</sub>	-	13	-	ns	
Turn-off delay time	t <sub>d(off)</sub>	-	64	-	ns	
Fall time	t <sub>f</sub>	-	8	-	ns	

<sup>4)</sup> GATE CHARGE CHARACTERISTICS

PARAMETER	Symbol	Min.	Typ.	Max.	Unit	Conditions / Note
Gate to source charge	Q <sub>gs</sub>	-	34	-	nC	V <sub>DD</sub> =100 V, I <sub>D</sub> =50 A, V <sub>GS</sub> =0 to 10 V
Gate charge at threshold	Q <sub>gs(th)</sub>	-	19	-	nC	
Gate to drain charge	Q <sub>gd</sub>	-	9	-	nC	
Switching charge	Q <sub>sw</sub>	-	24	-	nC	
Gate charge total	Q <sub>g</sub>	-	80	-	nC	
Gate plateau voltage	V <sub>plateau</sub>	-	5.4	-	V	

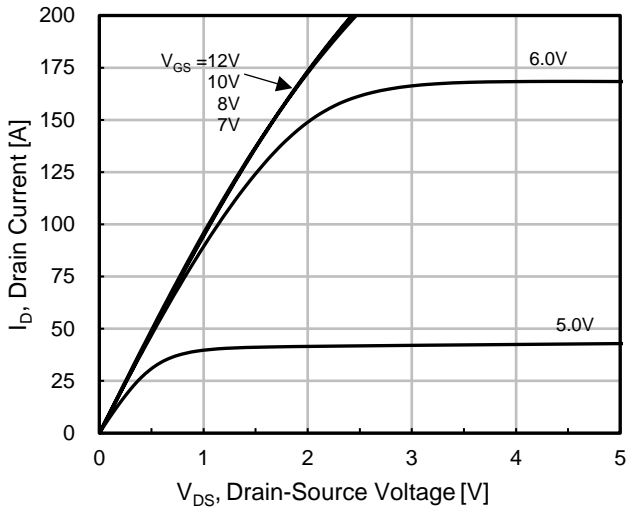
## SOURCE-DRAIN DIODE

PARAMETER	Symbol	Min.	Typ.	Max.	Unit	Conditions / Note
<sup>4)</sup> Diode continuous forward current	I <sub>S</sub>	-	-	95	A	-
<sup>4)</sup> Diode pulse current	I <sub>S,pulse</sub>	-	-	380	A	pulsed; t <sub>p</sub> ≤ 10 μs
Diode forward voltage	V <sub>SD</sub>	-	0.86	1.20	V	V <sub>GS</sub> =0 V, I <sub>F</sub> =50 A
<sup>4)</sup> Reverse recovery time	t <sub>rr</sub>	-	148	-	ns	I <sub>F</sub> =50 A, d <sub>I</sub> /dt=100 A/μs
<sup>4)</sup> Reverse recovery charge	Q <sub>rr</sub>	-	785	-	nC	I <sub>F</sub> =50 A, d <sub>I</sub> /dt=100 A/μs

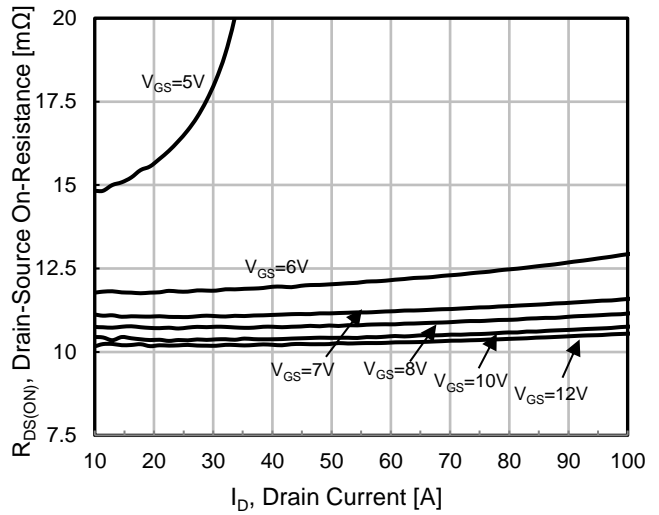
## Notes

- Pulse width limited by T<sub>Jmax</sub>
- Starting T<sub>J</sub>=25°C, L=1mH, I<sub>AS</sub>=27A, V<sub>DD</sub>=50V, V<sub>GS</sub>=10V
- Surface mounted FR-4 board by JEDEC (jesd51-7)
- The parameter is not subject to production testing - guaranteed by design.

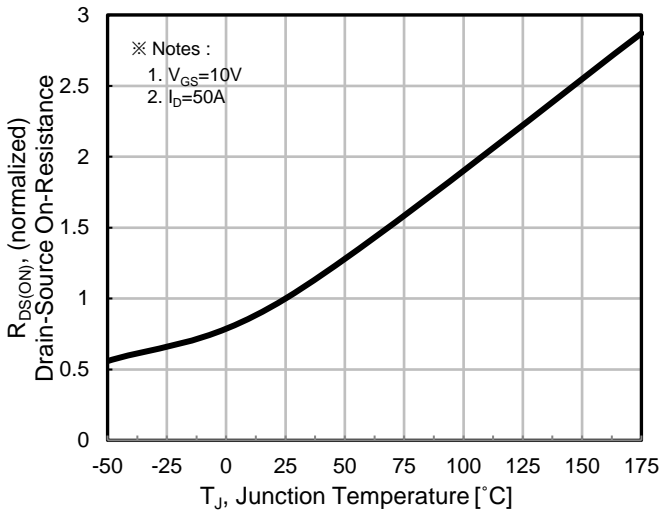
**ELECTRICAL CHARACTERISTICS DIAGRAMS**



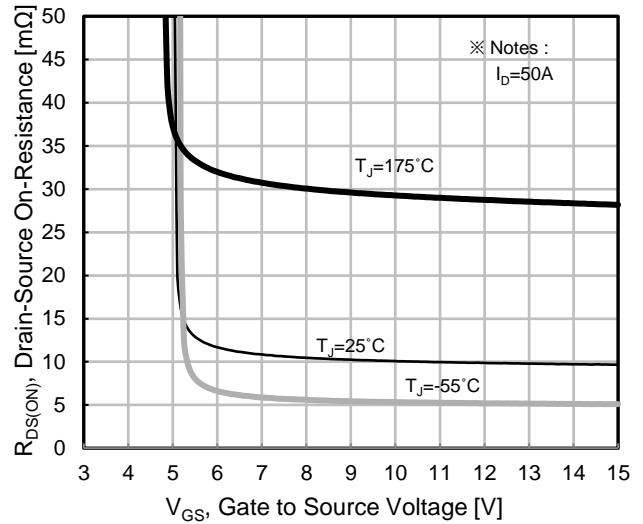
**Fig. 1. Typ. Output Characteristics**



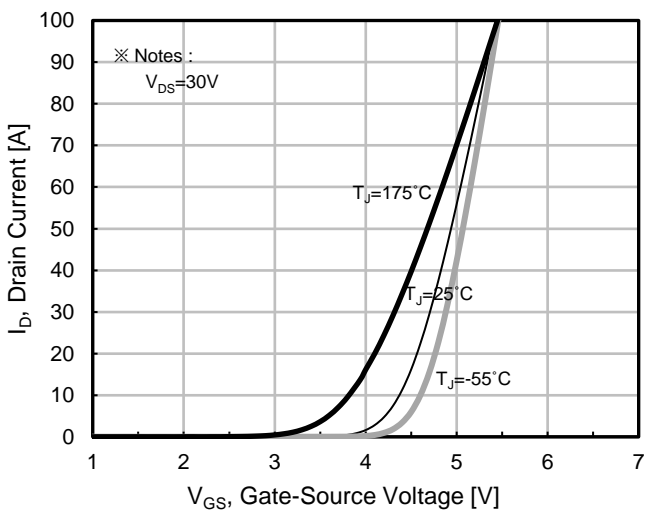
**Fig. 2. Typ. Drain to Source On-Resistance**



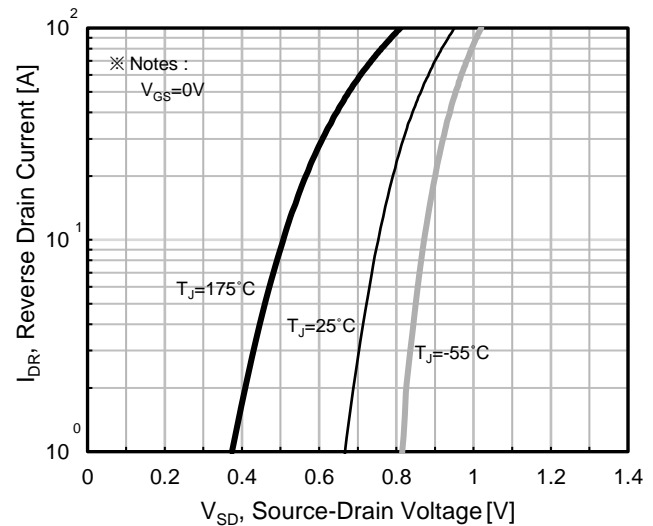
**Fig. 3. On-Resistance vs. Junction Temperature**



**Fig. 4. On-Resistance vs. Gate to Source Voltage**

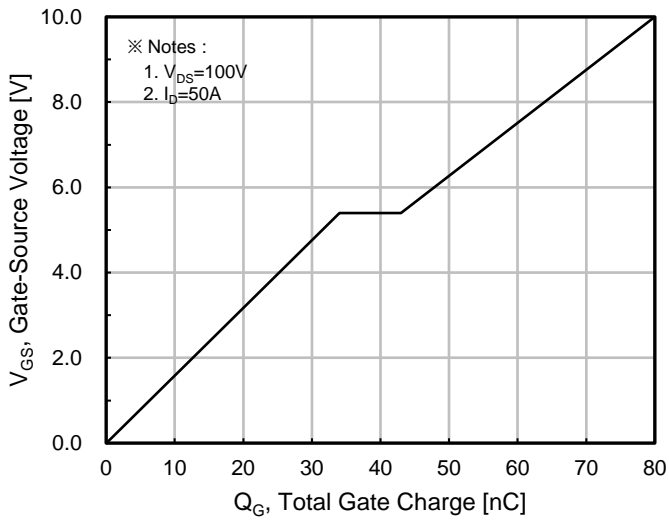


**Fig. 5. Typ. Transfer Characteristics**

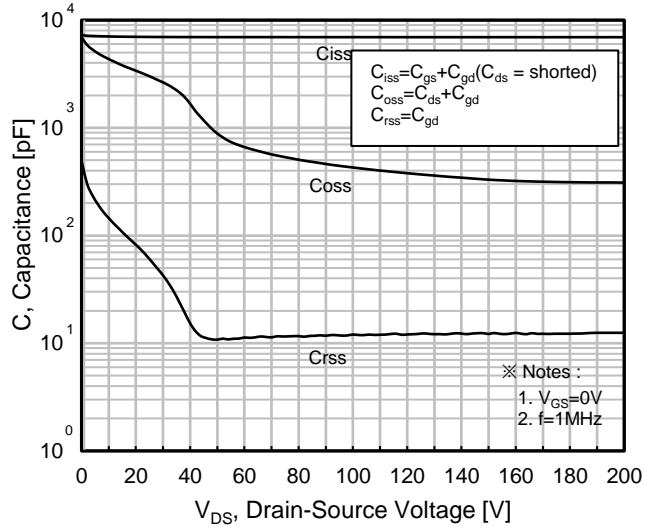


**Fig. 6. Forward Characteristics of Reverse Diode**

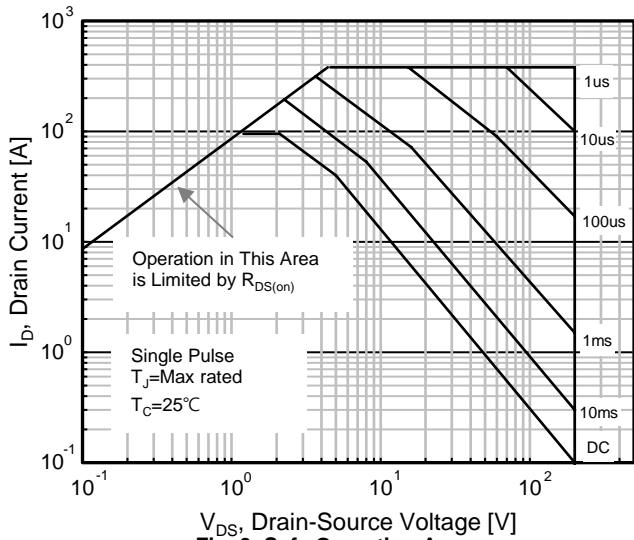
**ELECTRICAL CHARACTERISTICS DIAGRAMS**



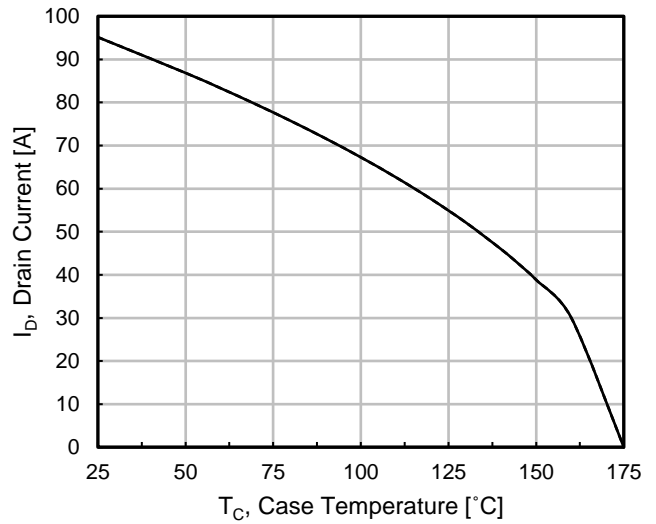
**Fig. 7. Typ. Gate Charge**



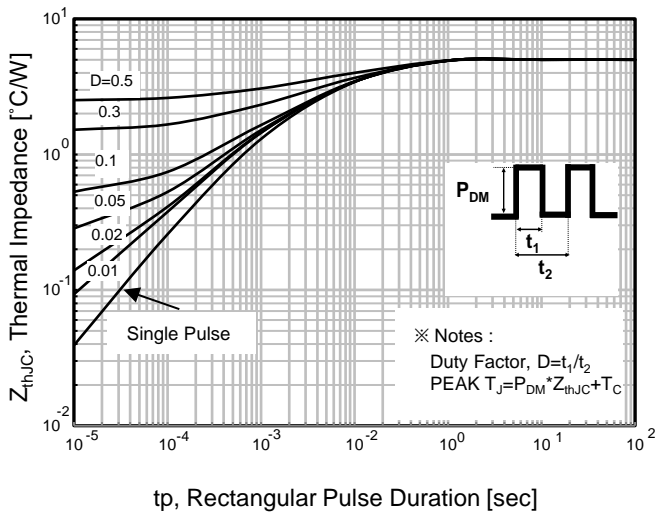
**Fig. 8. Typ. Capacitances**



**Fig. 9. Safe Operating Area**



**Fig. 10. Drain Current vs. Temperature**



**Fig. 11. Transient Thermal Impedance**

## ELECTRICAL CHARACTERISTICS DIAGRAMS

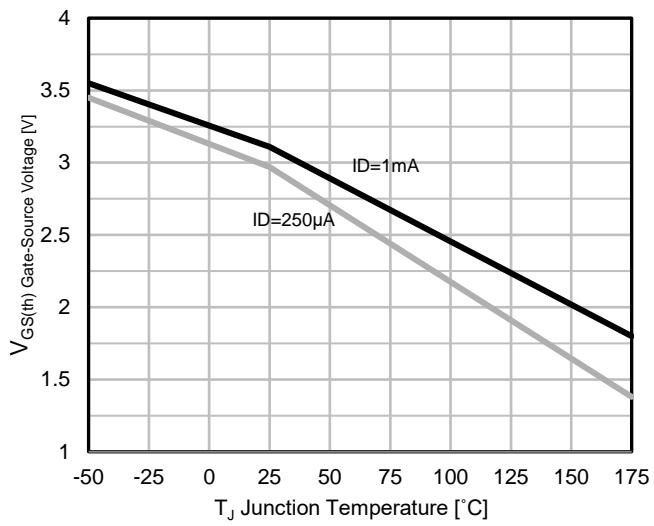


Fig.12 Gate-Source Threshold Voltage vs. Temperature

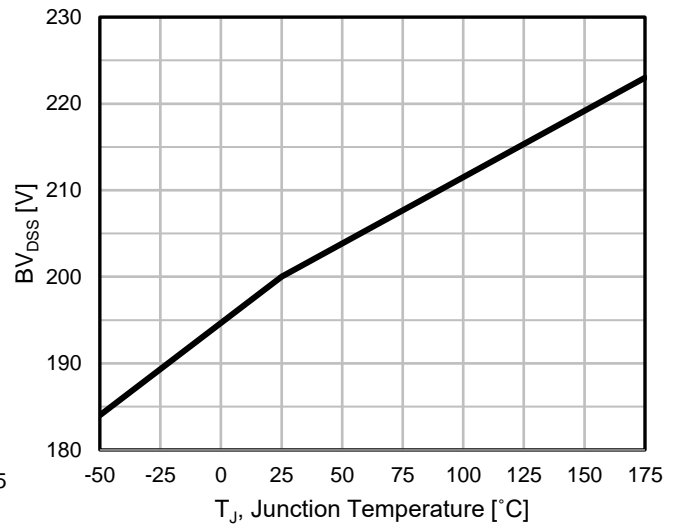
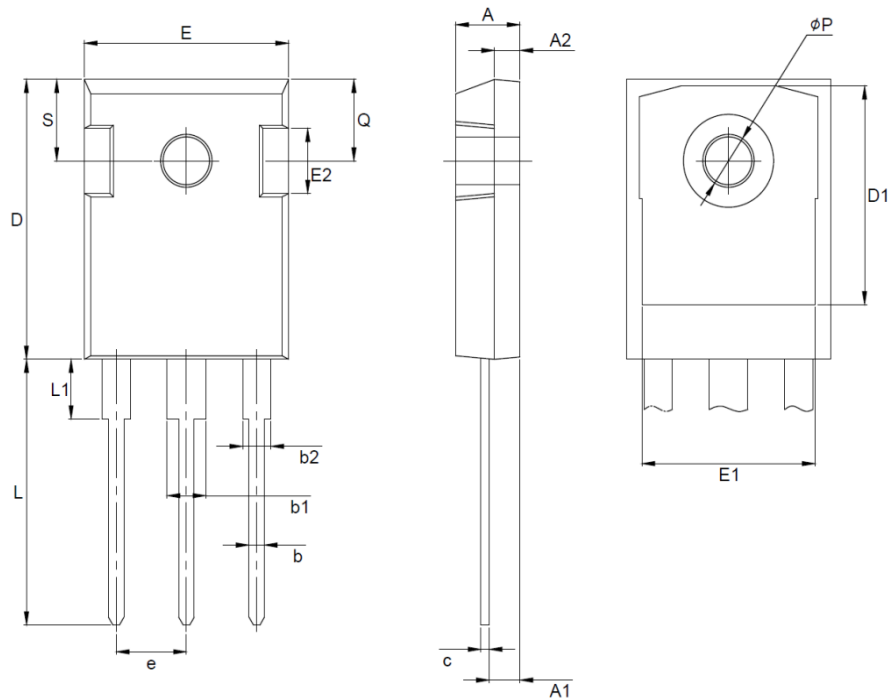


Fig.13 Drain-Source Voltage vs. Temperature

# Package Outlines

## TO-247




Symbol	Dimension (mm)		
	Min	Nom	Max
A	4.70	-	5.31
A1	2.20	-	2.60
A2	1.50	-	2.49
b	0.99	-	1.40
b1	2.59	-	3.43
b2	1.65	-	2.39
c	0.38	-	0.89
D	20.30	-	21.46
D1	13.08	-	-
E	15.45	-	16.26
E1	13.06	-	14.15
E2	4.32	-	5.49
e	5.45 BSC		
L	19.81	-	20.57
L1	-	-	4.50
$\phi P$	3.50	-	3.70
Q	5.38	-	6.20
S	6.15 BSC		

### Notes

Package body size, length and width do not include mold flash, protrusions and gate burrs.

**DISCLAIMER :**

The Products are not designed for use in hostile environments, including, without limitation, aircraft, nuclear power generation, medical appliances, and devices or systems in which malfunction of any Product can reasonably be expected to result in a personal injury. Seller's customers using or selling Seller's products for use in such applications do so at their own risk and agree to fully defend and indemnify Seller.

Magnachip reserves the right to change the specifications and circuitry without notice at any time. Magnachip does not consider responsibility for use of any circuitry other than circuitry entirely included in a Magnachip product.  Magnachip are registered trademarks of Magnachip Semiconductor Ltd.