

# MMF70R900Q

## 700V 0.9Ω N-channel MOSFET

### ■ Description

MMF70R900Q is power MOSFET using Magnachip's advanced super junction technology that can realize very low on-resistance and gate charge. It will provide much high efficiency by using optimized charge coupling technology. These user friendly devices give an advantage of Low EMI to designers as well as low switching loss.

### ■ Key Parameters

Parameter	Value	Unit
$V_{DS} @ T_{j,max}$	750	V
$R_{DS(on),max}$	0.9	Ω
$V_{TH,typ}$	3	V
$I_D$	5	A
$Q_{g,typ}$	11	nC

### ■ Package & Internal Circuit

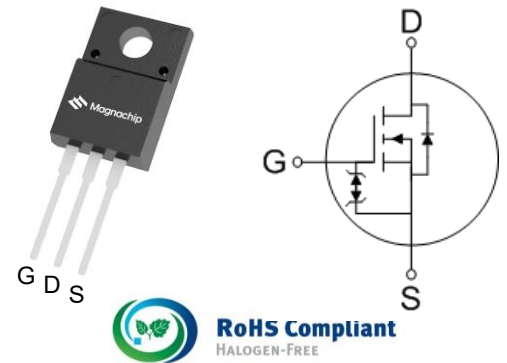

### ■ Features

- Low Power Loss by High Speed Switching and Low On-Resistance
- Excellent ESD robustness
- 100% Avalanche Tested
- Green Package – Pb Free Plating, Halogen Free
- Product validation acc. JEDEC Standard

### ■ Applications

- PFC Power Supply Stages
- Switching Applications
- Adapter

### ■ Ordering Information

Order Code	Marking	Temp. Range	Package	Packing	RoHS Status
MMF70R900QTH	70R900Q	-55 ~ 150°C	TO-220F(3L)	Tube	Compliant

**■ Absolute Maximum Rating ( $T_c=25^\circ\text{C}$  unless otherwise specified)**

Parameter	Symbol	Rating	Unit	Note
Drain – Source voltage	$V_{DSS}$	700	V	
Gate – Source voltage	$V_{GSS}$	$\pm 30$	V	
Continuous drain current	$I_D$	5	A	$T_c=25^\circ\text{C}$
		3	A	$T_c=100^\circ\text{C}$
Pulsed drain current <sup>(1)</sup>	$I_{DM}$	15	A	
Power dissipation	$P_D$	21	W	
Single - pulse avalanche energy	$E_{AS}$	45	mJ	
MOSFET dv/dt ruggedness	dv/dt	50	V/ns	
Diode dv/dt ruggedness <sup>(2)</sup>	dv/dt	15	V/ns	
Storage temperature	$T_{stg}$	-55 ~150	$^\circ\text{C}$	
Maximum operating junction temperature	$T_j$	150	$^\circ\text{C}$	

1) Pulse width  $t_P$  limited by  $T_{j,max}$

2)  $I_{SD} \leq I_D, V_{DS\ peak} \leq V_{(BR)DSS}$

**■ Thermal Characteristics**

Parameter	Symbol	Value	Unit	Note
Thermal resistance, junction-case max	$R_{thjc}$	5.9	$^\circ\text{C/W}$	
Thermal resistance, junction-ambient max	$R_{thja}$	75	$^\circ\text{C/W}$	
Soldering temperature, wavesoldering only allowed at leads <sup>(3)</sup>	$T_{sold}$	260	$^\circ\text{C}$	1.6mm (0.063 in.) from case for 10s

1) This parameter can be changed according to internal circumstances

**■ Static Characteristics (T<sub>c</sub>=25°C unless otherwise specified)**

Parameter	Symbol	Min.	Typ.	Max.	Unit	Test Condition
Drain – Source Breakdown voltage	V <sub>(BR)DSS</sub>	700	-	-	V	V <sub>GS</sub> = 0V, I <sub>D</sub> = 0.25mA
Gate Threshold Voltage	V <sub>GS(th)</sub>	2	3	4	V	V <sub>DS</sub> = V <sub>GS</sub> , I <sub>D</sub> = 0.25mA
Zero Gate Voltage Drain Current	I <sub>DSS</sub>	-	-	1	uA	V <sub>DS</sub> = 700V, V <sub>GS</sub> = 0V
Gate Leakage Current	I <sub>GSS</sub>	-	-	100	nA	V <sub>GS</sub> = ±30V, V <sub>DS</sub> = 0V
Drain-Source On State Resistance	R <sub>DS(ON)</sub>	-	0.81	0.9	Ω	V <sub>GS</sub> = 10V, I <sub>D</sub> = 1.5A

**■ Dynamic Characteristics (T<sub>c</sub>=25°C unless otherwise specified)**

Parameter	Symbol	Min.	Typ.	Max.	Unit	Test Condition
Input Capacitance	C <sub>iss</sub>	-	368	-	pF	V <sub>DS</sub> = 100V, V <sub>GS</sub> = 0V, f = 400kHz
Output Capacitance	C <sub>oss</sub>	-	16	-		
Reverse Transfer Capacitance	C <sub>rss</sub>	-	1.2	-		
Effective Output Capacitance Energy Related <sup>(4)</sup>	C <sub>o(er)</sub>	-	11	-		V <sub>DS</sub> = 0V to 560V, V <sub>GS</sub> = 0V, f = 1.0MHz
Turn On Delay Time	t <sub>d(on)</sub>	-	11	-	ns	V <sub>GS</sub> = 10V, R <sub>G</sub> = 25Ω, V <sub>DS</sub> = 350V, I <sub>D</sub> = 5A
Rise Time	t <sub>r</sub>	-	19	-		
Turn Off Delay Time	t <sub>d(off)</sub>	-	64	-		
Fall Time	t <sub>f</sub>	-	19	-		
Total Gate Charge	Q <sub>g</sub>	-	11	-	nC	V <sub>GS</sub> = 10V, V <sub>DS</sub> = 560V, I <sub>D</sub> = 5A
Gate – Source Charge	Q <sub>gs</sub>	-	2.8	-		
Gate – Drain Charge	Q <sub>gd</sub>	-	4.1	-		
Gate Resistance	R <sub>G</sub>	-	21	-	Ω	V <sub>GS</sub> = 0V, f = 1.0MHz

4) C<sub>o(er)</sub> is a capacitance that gives the same stored energy as C<sub>oss</sub> while V<sub>DS</sub> is rising from 0V to 80% V<sub>(BR)DSS</sub>

**■ Reverse Diode Characteristics ( $T_c=25^\circ\text{C}$  unless otherwise specified)**

Parameter	Symbol	Min.	Typ.	Max.	Unit	Test Condition
Continuous Diode Forward Current	$I_{SD}$	-	-	7.3	A	
Diode Forward Voltage	$V_{SD}$	-	-	1.4	V	$I_{SD} = 5\text{A}$ , $V_{GS} = 0\text{V}$
Reverse Recovery Time	$t_{rr}$	-	265	-	ns	$I_{SD} = 5\text{A}$ $di/dt = 100\text{A}/\mu\text{s}$ $V_{DD} = 100\text{V}$
Reverse Recovery Charge	$Q_{rr}$	-	1.9	-	$\mu\text{C}$	
Reverse Recovery Current	$I_{rrm}$	-	14.1	-	A	

■ Characteristic Graph

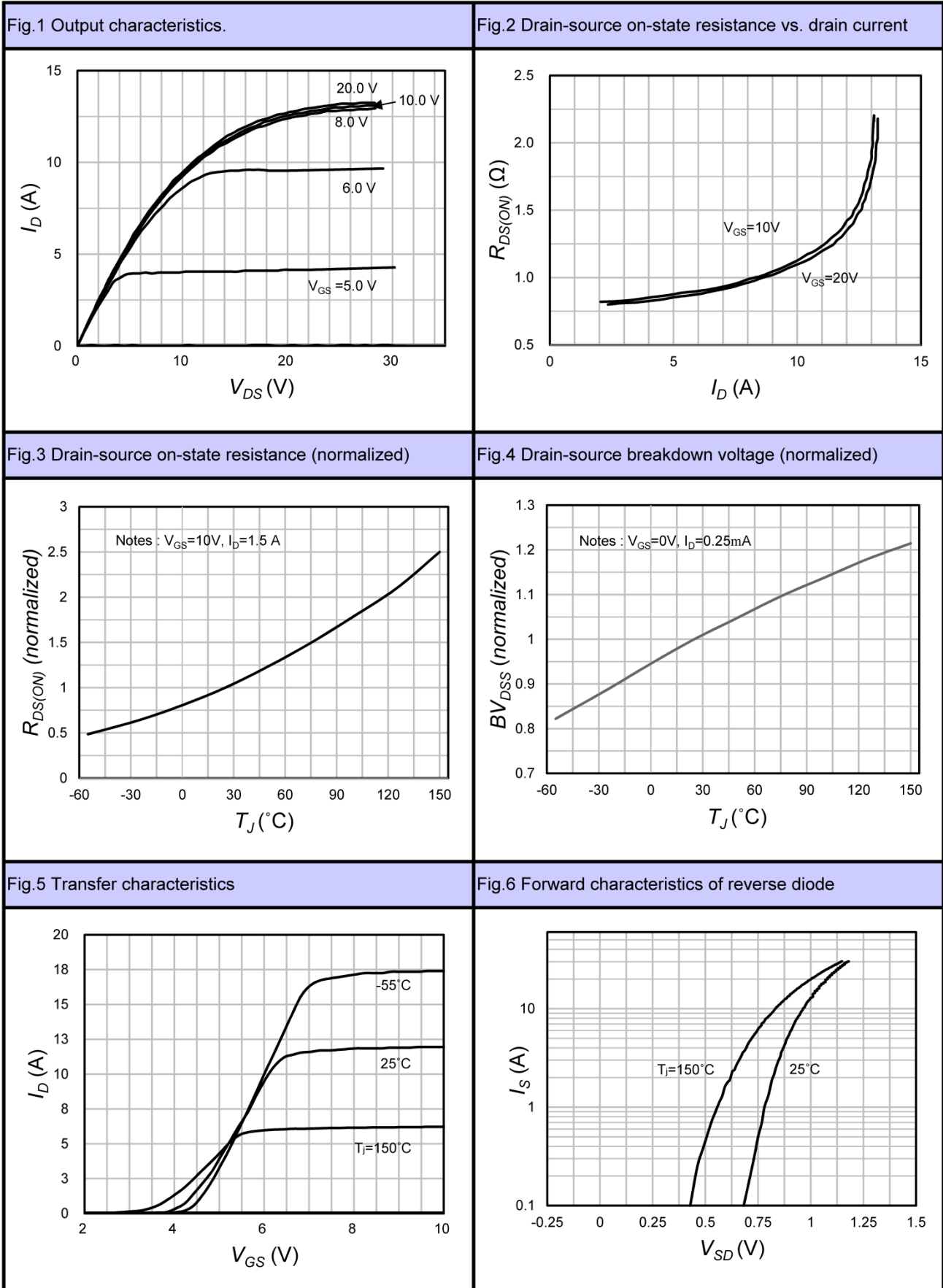

Fig.7 Gate charge

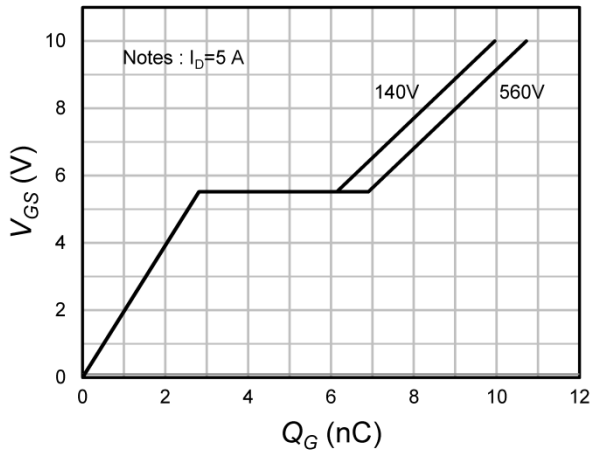

Fig.8 Capacitance characteristics

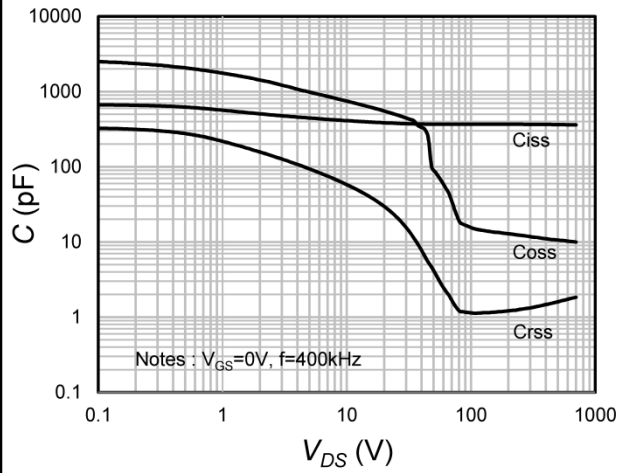

Fig.9 VGS(th) variation vs. temprature (nomalized)

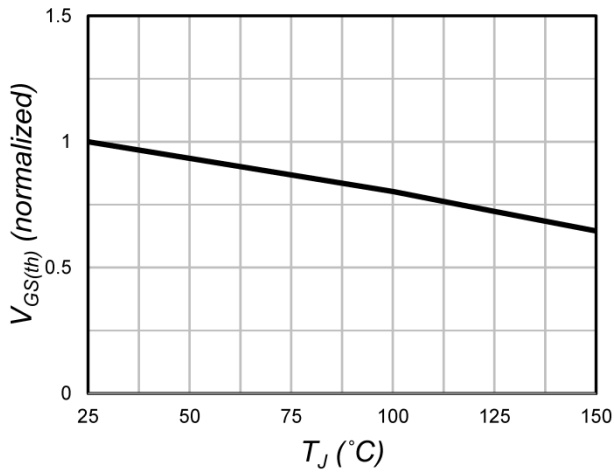

Fig.10 Maximum drain current vs. case temperature

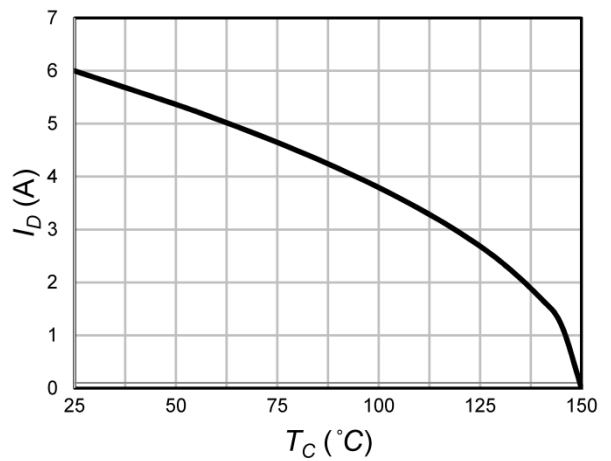

Fig.11 Power dissipation

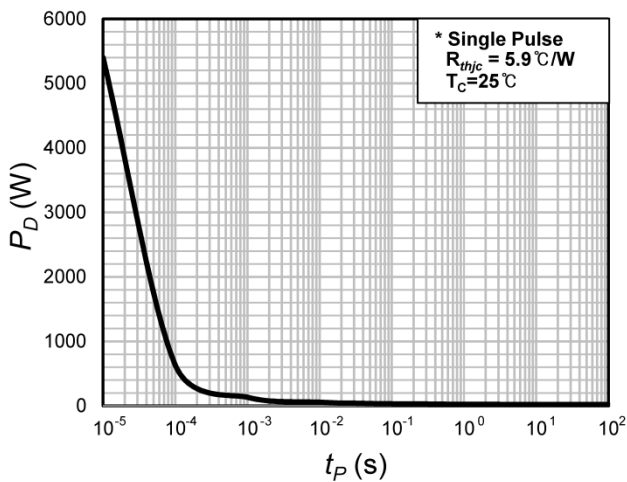

Fig.12 Output capacitance stored energy

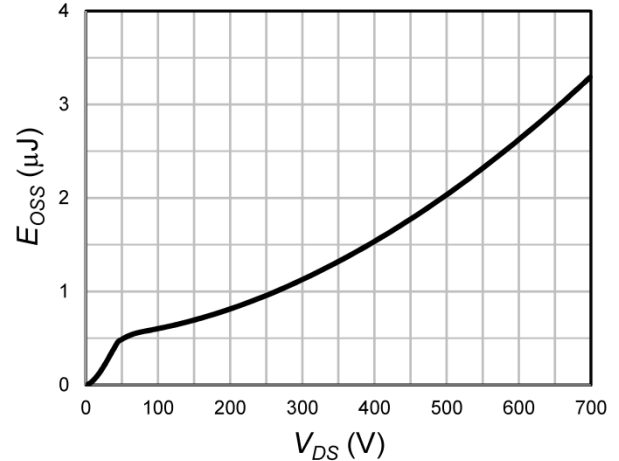

Fig.13 Transient thermal impedance

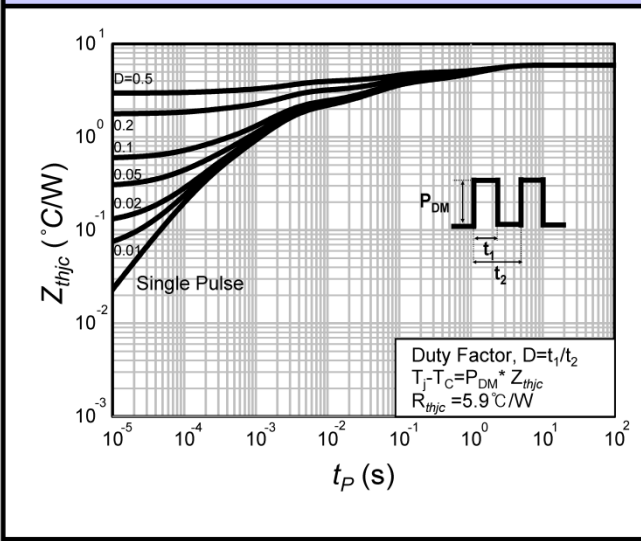
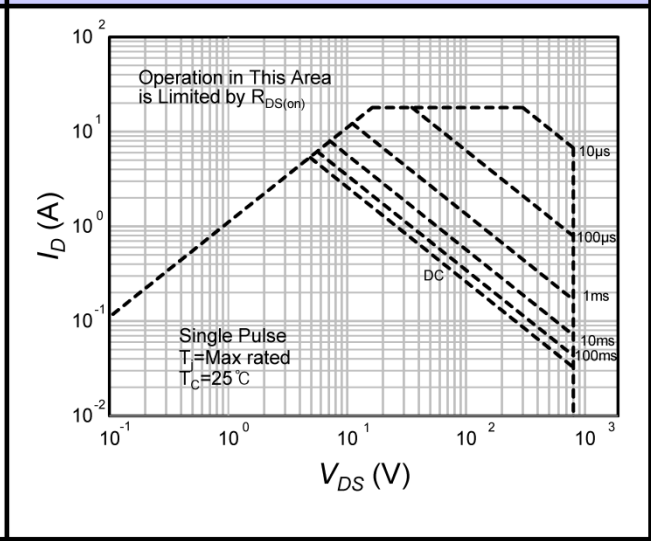

Fig.14 Safe operating area



■ Test Circuit

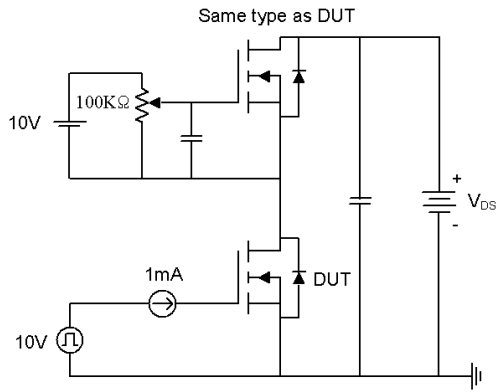

Fig15-1. Gate charge measurement circuit

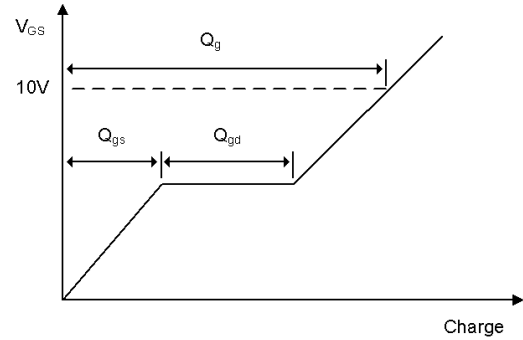

Fig15-2. Gate charge waveform

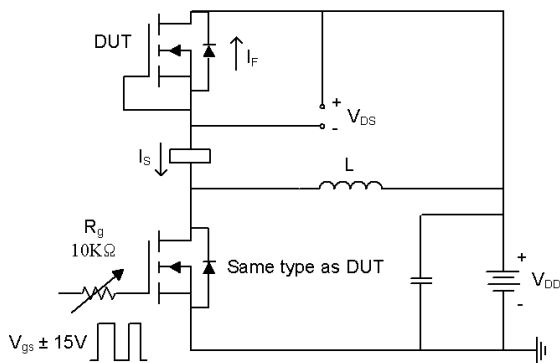

Fig16-1. Diode reverse recovery test circuit

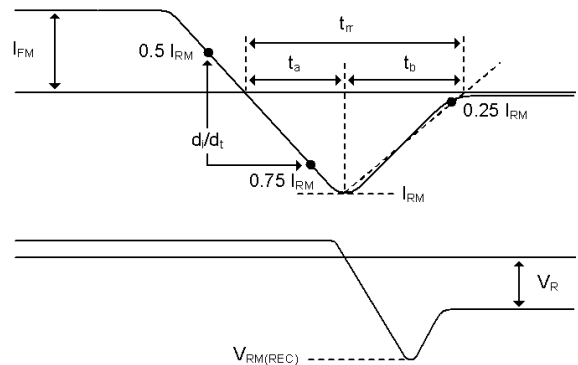

Fig16-2. Diode reverse recovery test waveform

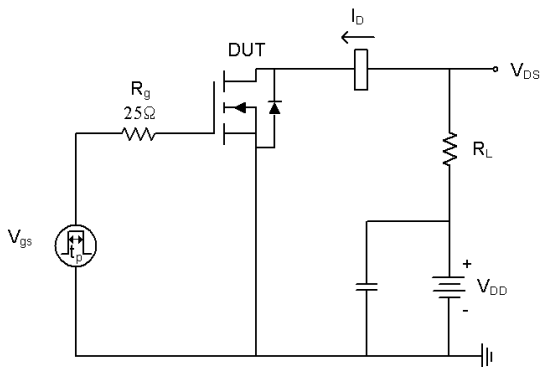

Fig17-1. Switching time test circuit for resistive load

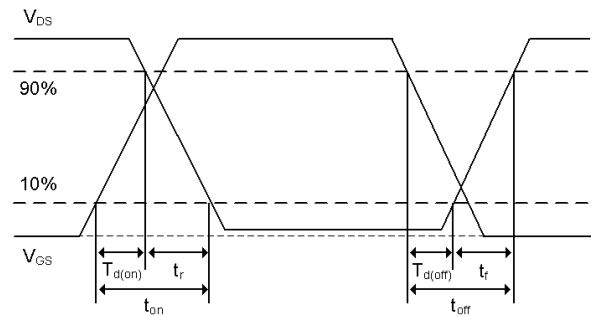

Fig17-2. Switching time waveform

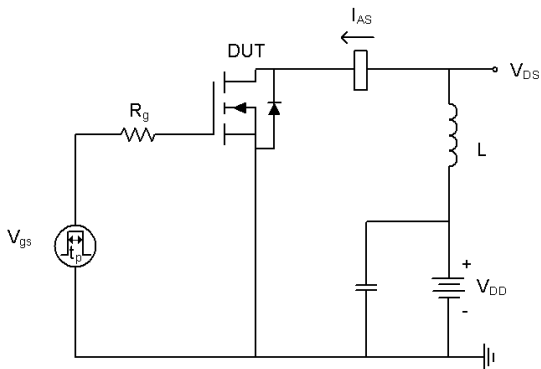

Fig18-1. Unclamped inductive load test circuit

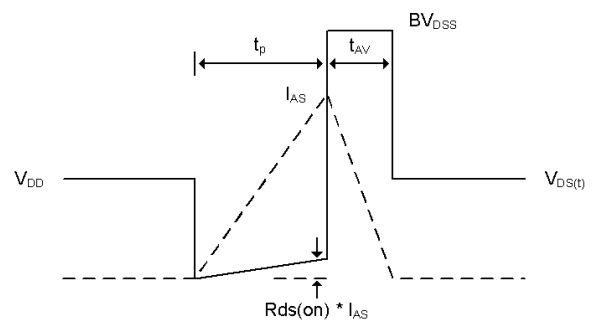
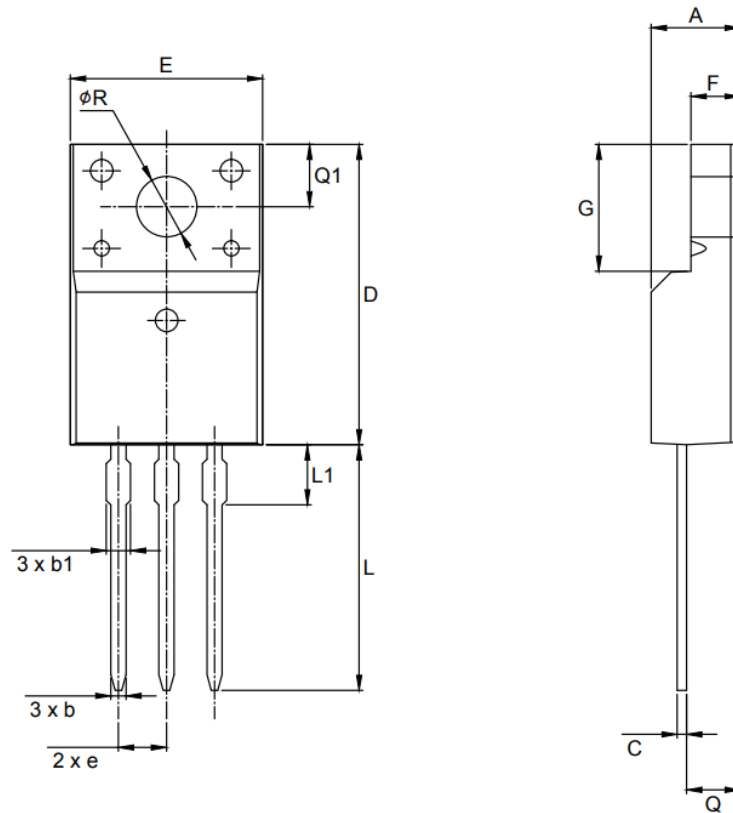

Fig18-2. Unclamped inductive waveform



**■ Physical Dimension**
**TO-220F(3L)**

Symbol	Dimension (mm)		
	Min	Nom	Max
A	4.50	-	4.93
b	0.63	-	0.91
b1	1.15	-	1.47
C	0.33	-	0.63
D	15.47	-	16.13
E	9.60	-	10.71
e	2.54 BSC		
F	2.34	-	2.84
G	6.48	-	6.90
L	12.24	-	13.72
L1	2.79	-	3.67
Q	2.52	-	2.96
Q1	3.10	-	3.50
∅R	3.00	-	3.55

Note : Package body size, length and width do not include mold flash, protrusions and gate burrs.

**DISCLAIMER:**

The Products are not designed for use in hostile environments, including, without limitation, aircraft, nuclear power generation, medical appliances, and devices or systems in which malfunction of any Product can reasonably be expected to result in a personal injury. Seller's customers using or selling Seller's products for use in such applications do so at their own risk and agree to fully defend and indemnify Seller.

Magnachip reserves the right to change the specifications and circuitry without notice at any time. Magnachip does not consider responsibility for use of any circuitry other than circuitry entirely included in a Magnachip product.  Magnachip is a registered trademark of Magnachip Semiconductor Ltd.