

MMFA60R1K0RFZ

600V 1.0Ω N-channel MOSFET

■ Description

MMF60R1K0RFZ is power MOSFET using Magnachip's advanced super junction technology that can realize very low on-resistance and gate charge. It will provide much high efficiency by using optimized charge coupling technology. These user friendly devices give an advantage of Low EMI to designers as well as low switching loss.

■ Key Parameters

Parameter	Value	Unit
$V_{DS} @ T_{j,max}$	650	V
$R_{DS(on),max}$	1.0	Ω
$V_{TH,typ}$	4.0	V
I_D	3.0	A
$Q_{g,typ}$	7.2	nC

■ Features

- Ultra-fast Body Diode
- Low Power Loss by High Speed Switching and Low On-Resistance
- 100% Avalanche Tested
- Green Package – Pb Free Plating, Halogen Free
- Zener - Integrated

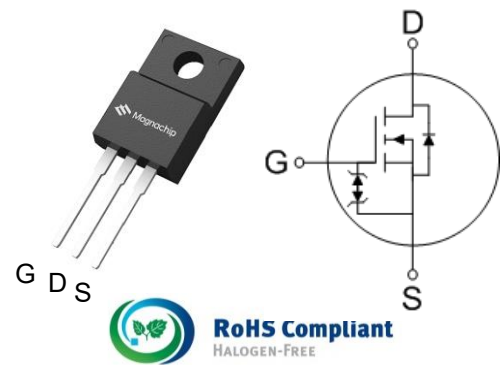
■ Applications

- Soft-switching Applications
- Server Power Supply
- Telecom
- EV charging

■ Ordering Information

Order Code	Marking	Temp. Range	Package	Packing	RoHS Status
MMFA60R1K0RFZTH	A60R1K0RFZ	-55 ~ 150°C	TO-220FA	Tube	Halogen Free

■ Package & Internal Circuit



■ Absolute Maximum Rating ($T_c=25^\circ\text{C}$ unless otherwise specified)

Parameter	Symbol	Rating	Unit	Note
Drain – Source voltage	V_{DSS}	600	V	
Gate – Source voltage	V_{GSS}	± 25	V	
Continuous drain current	I_D	3.0	A	$T_c=25^\circ\text{C}$
		1.9	A	$T_c=100^\circ\text{C}$
Pulsed drain current ⁽¹⁾	I_{DM}	9.0	A	
Power dissipation	P_D	25.7	W	
Single - pulse avalanche energy	E_{AS}	100	mJ	
MOSFET dv/dt ruggedness	dv/dt	50	V/ns	
Diode dv/dt ruggedness ⁽²⁾	dv/dt	50	V/ns	
Storage temperature	T_{stg}	-55 ~150	$^\circ\text{C}$	
Maximum operating junction temperature	T_j	150	$^\circ\text{C}$	

- 1) I_D limited by maximum junction temperature
- 2) Pulse width t_P limited by $T_{j,max}$
- 3) $I_{AS} : 1.0 \text{ A}$
- 4) $I_{SD} \leq I_D$, $di/dt = 500 \text{ A}/\mu\text{s}$, $V_{DS,peak} \leq V_{(BR)DSS}$, $V_{DD} = 400 \text{ V}$, $T_j = 25^\circ\text{C}$

■ Thermal Characteristics

Parameter	Symbol	Value	Unit
Thermal resistance, junction-case max	R_{thjc}	4.87	$^\circ\text{C}/\text{W}$
Thermal resistance, junction-ambient max	R_{thja}	68.8	$^\circ\text{C}/\text{W}$

■ Static Characteristics (T_c=25°C unless otherwise specified)

Parameter	Symbol	Min.	Typ.	Max.	Unit	Test Condition
Drain – Source Breakdown voltage	V _{(BR)DSS}	600	-	-	V	V _{GS} = 0V, I _D = 1mA
Gate Threshold Voltage	V _{GS(th)}	3.0	4.0	5.0	V	V _{DS} = V _{GS} , I _D = 250μA
Zero Gate Voltage Drain Current	I _{DSS}	-	-	8	μA	V _{DS} = 600V, V _{GS} = 0V
Gate Leakage Current	I _{GSS}	-	-	10	μA	V _{GS} = ±25V, V _{DS} = 0V
Drain-Source On State Resistance	R _{DS(ON)}	-	0.91	1.01	Ω	V _{GS} = 10V, I _D = 1.5A

■ Dynamic Characteristics (T_c=25°C unless otherwise specified)

Parameter	Symbol	Min.	Typ.	Max.	Unit	Test Condition
Input Capacitance	C _{iss}	-	281	-	pF	V _{DS} = 400V, V _{GS} = 0V, f = 400kHz
Output Capacitance	C _{oss}	-	10	-		
Reverse Transfer Capacitance	C _{rss}	-	2	-		
Effective Output Capacitance Energy Related ⁽⁵⁾	C _{o(er)}	-	15	-		
Turn On Delay Time	t _{d(on)}	-	10.9	-	ns	V _{GS} = 10V, R _G = 25Ω, V _{DS} = 300V, I _D = 3A
Rise Time	t _r	-	16.1	-		
Turn Off Delay Time	t _{d(off)}	-	24.7	-		
Fall Time	t _f	-	9.8	-		
Total Gate Charge	Q _g	-	7.2	-	nC	V _{GS} = 10V, V _{DS} = 480V, I _D = 3A
Gate – Source Charge	Q _{gs}	-	2.5	-		
Gate – Drain Charge	Q _{gd}	-	2.9	-		
Gate Resistance	R _G	-	8.0	-	Ω	V _{GS} = 0V, f = 1MHz

5) C_{o(er)} is a capacitance that gives the same stored energy as C_{oss} while V_{DS} is rising from 0V to 80% V_{(BR)DSS}

■ Reverse Diode Characteristics ($T_c=25^\circ\text{C}$ unless otherwise specified)

Parameter	Symbol	Min.	Typ.	Max.	Unit	Test Condition
Continuous Diode Forward Current	I_{SD}	-	-	3.0	A	
Diode Forward Voltage	V_{SD}	-	-	1.4	V	$I_{SD} = 3\text{A}$, $V_{GS} = 0\text{V}$
Reverse Recovery Time	t_{rr}	-	138	-	ns	$I_{SD} = 3\text{A}$ $di/dt = 100\text{A}/\mu\text{s}$ $V_{DD} = 100\text{V}$
Reverse Recovery Charge	Q_{rr}	-	0.35	-	μC	
Reverse Recovery Current	I_{rrm}	-	5.2	-	A	

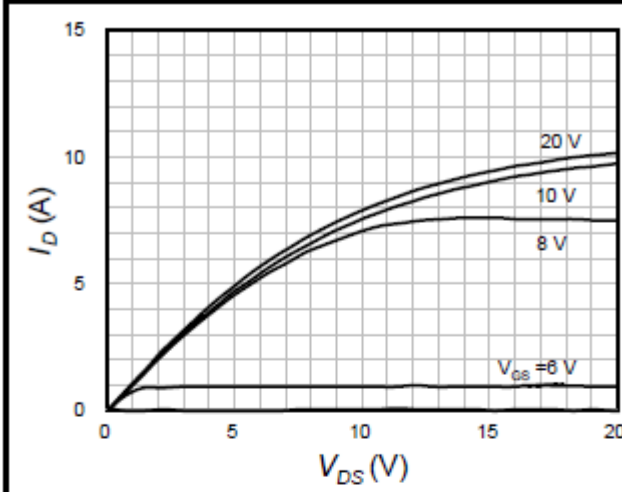
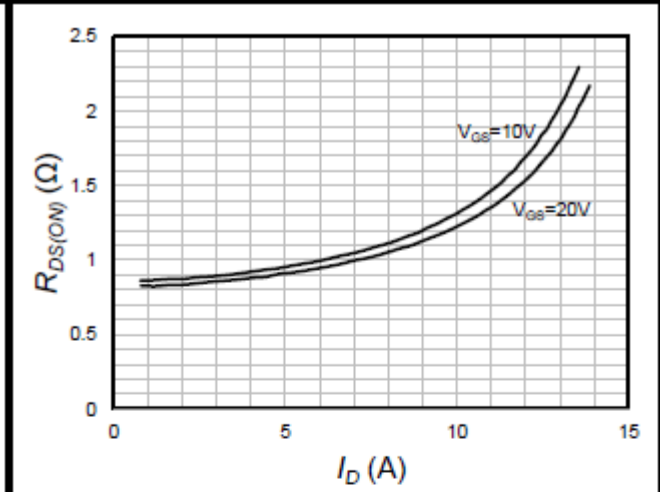
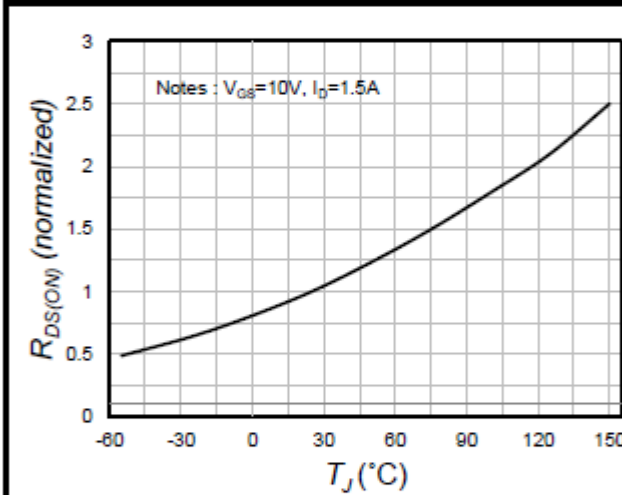
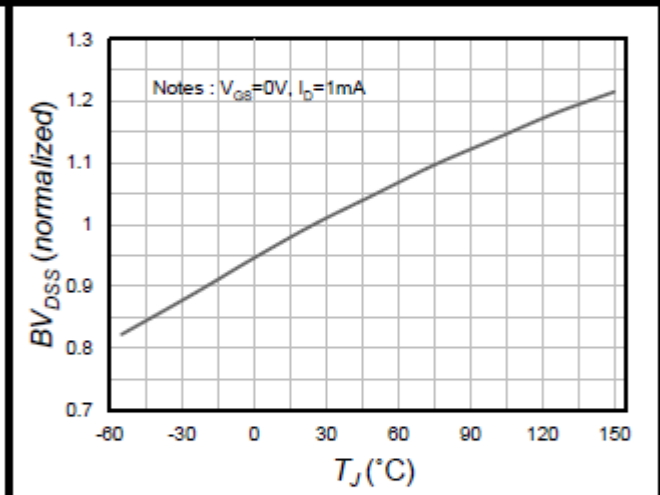
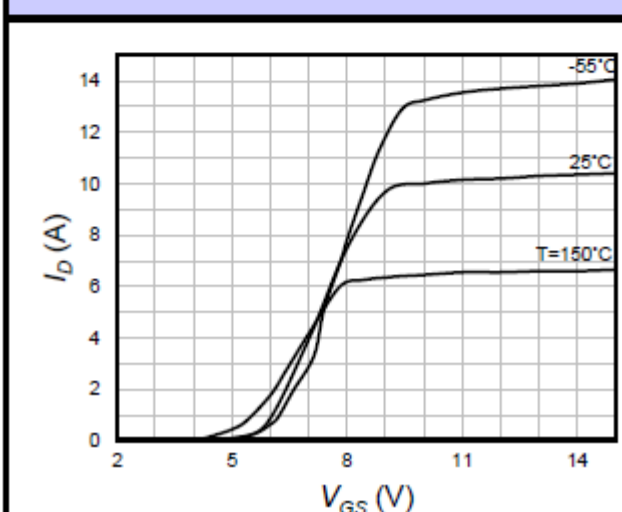
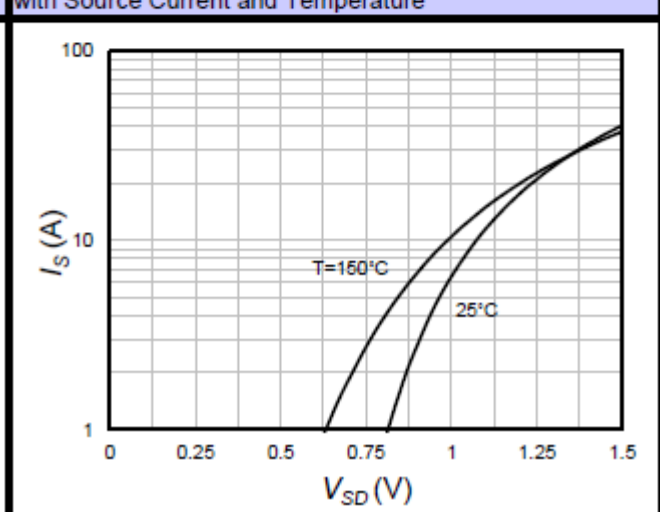
■ Characteristic Graph
Fig.1 On-Region Characteristics.

Fig.2 On-Resistance Variation with Drain Current and Gate Voltage

Fig.3 On-Resistance Variation with Temperature (Normalized)

Fig.4 Breakdown Voltage Variation vs. Temperature (Normalized)

Fig.5 Transfer Characteristics

Fig.6 Body Diode Forward Voltage Variation with Source Current and Temperature


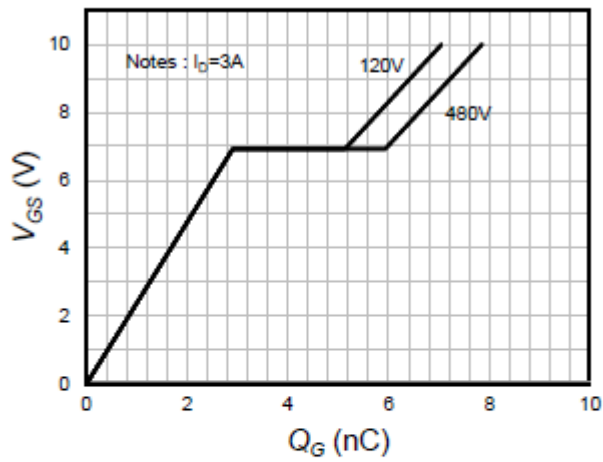
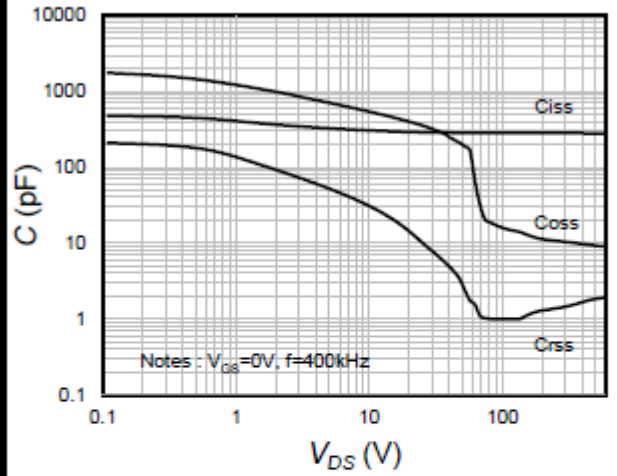
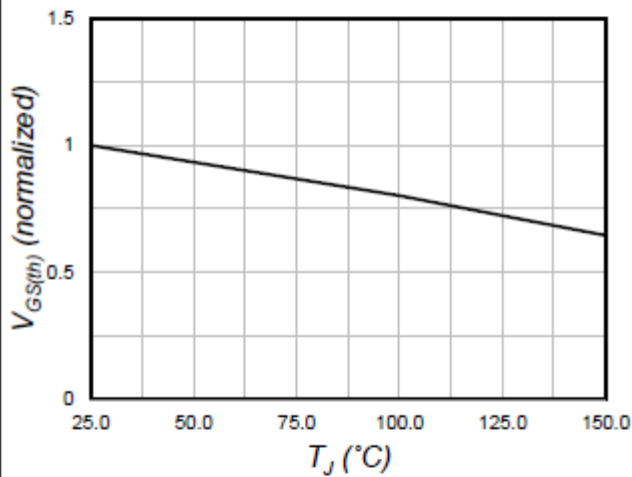
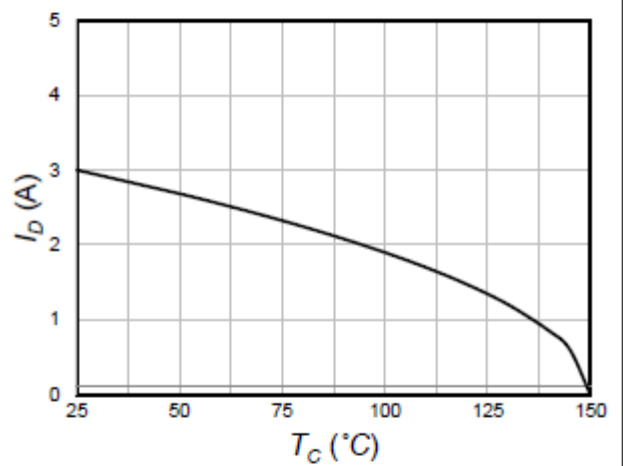
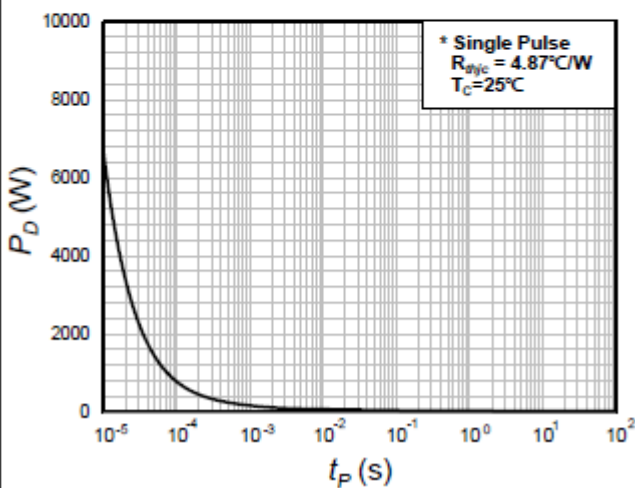
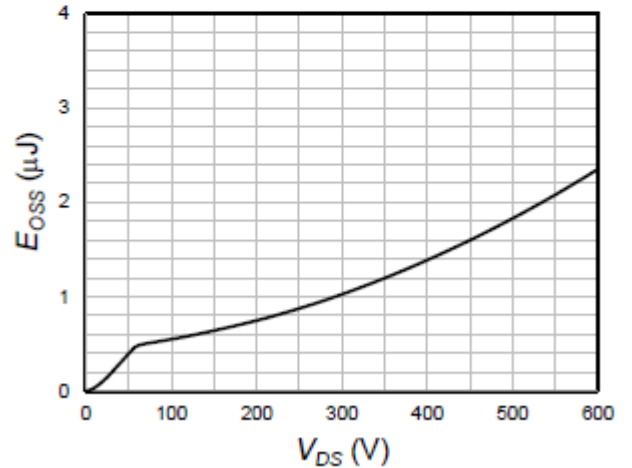
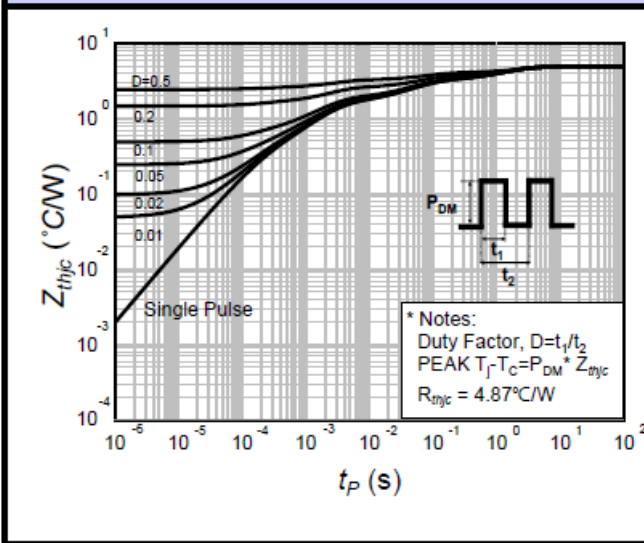
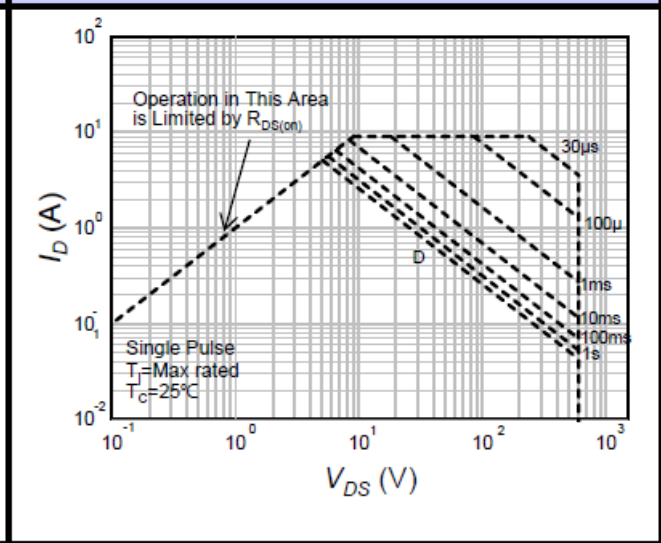
Fig.7 Gate Charge Characteristics

Fig.8 Capacitance Characteristics

Fig.9 $V_{GS(th)}$ Variation with Temperature (Normalized)

Fig.10 Maximum Drain Current vs. Case Temperature

Fig.11 Single Pulse Maximum Power Dissipation

Fig.12 Output Capacitance Stored Energy


Fig.13 Transient Thermal Response Curve

Fig.14 Maximum Safe Operating Area


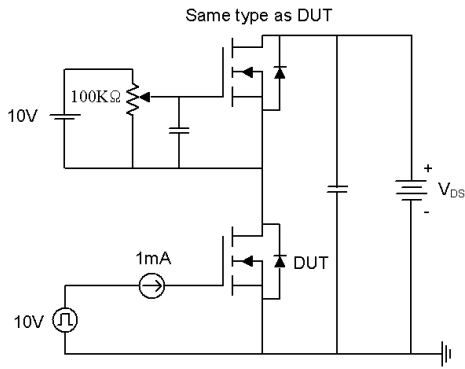
■ Test Circuit


Fig15-1. Gate charge measurement circuit

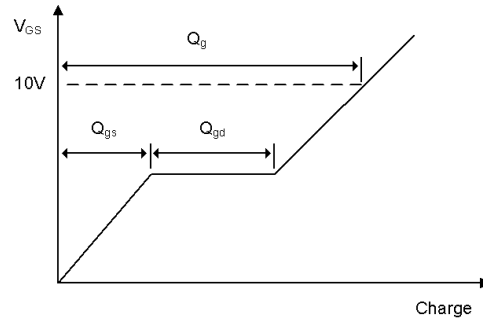


Fig15-2. Gate charge waveform

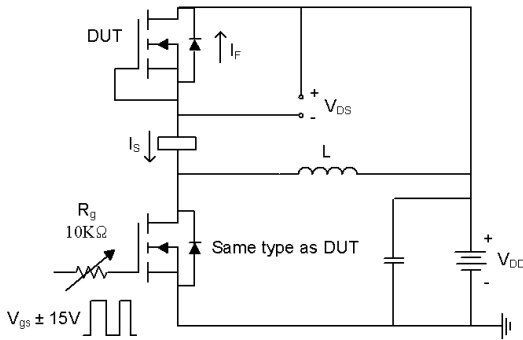


Fig16-1. Diode reverse recovery test circuit

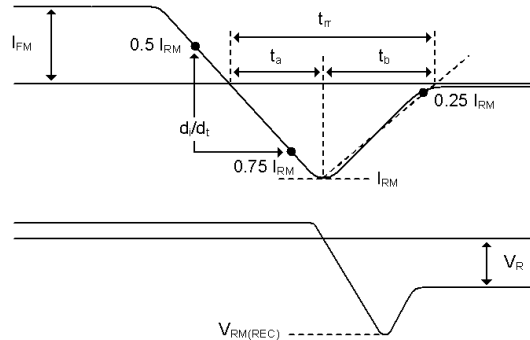


Fig16-2. Diode reverse recovery test waveform

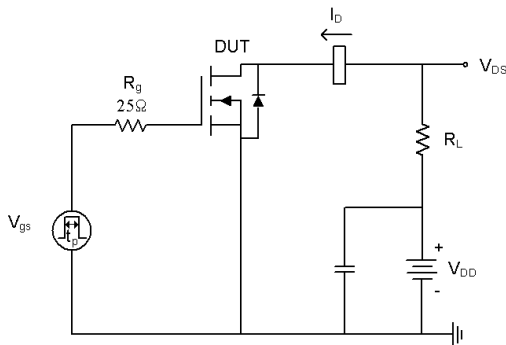


Fig17-1. Switching time test circuit for resistive load

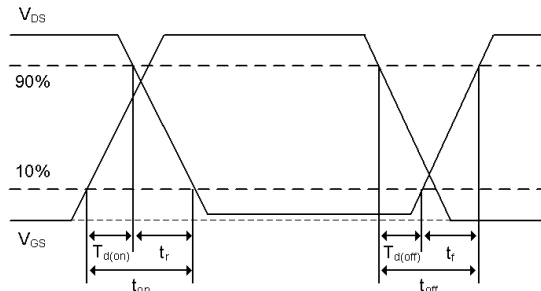


Fig17-2. Switching time waveform

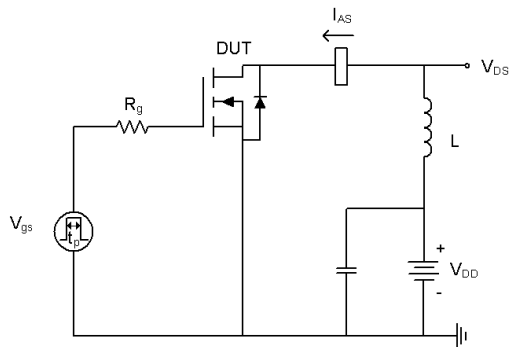


Fig18-1. Unclamped inductive load test circuit

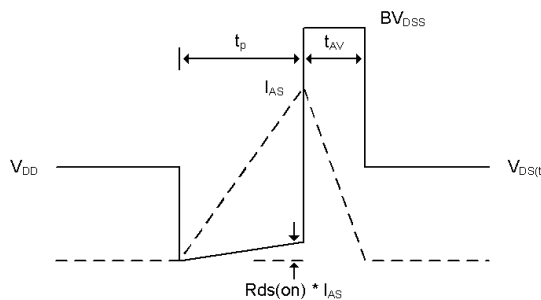
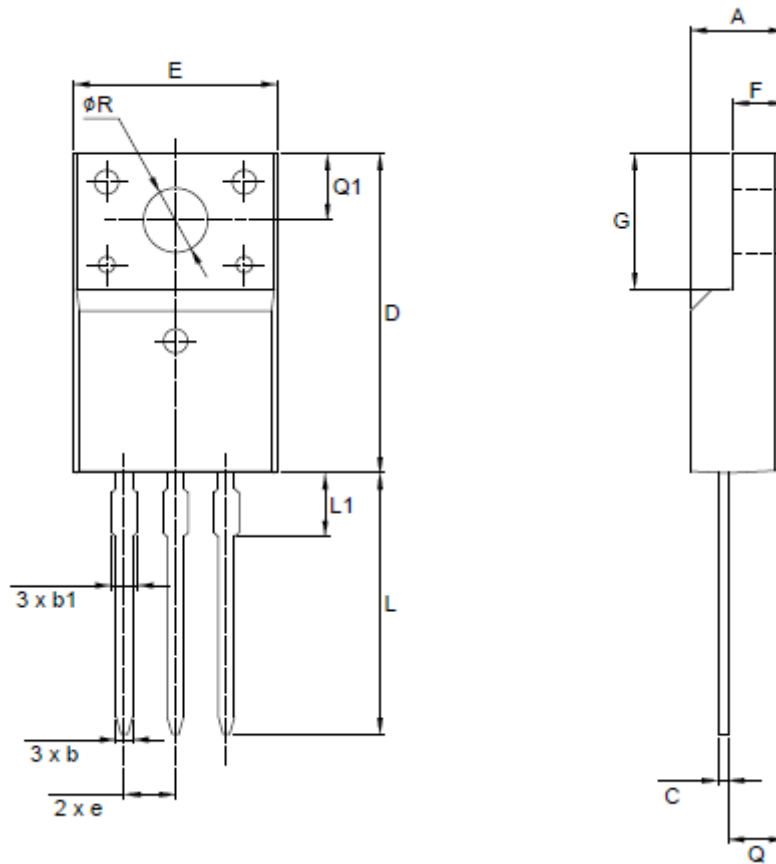


Fig18-2. Unclamped inductive waveform


■ Physical Dimension
TO-220FA (3L)


Symbol	Dimension (mm)		
	Min	Nom	Max
A	4.50	-	4.93
b	0.63	-	0.91
b1	1.15	-	1.47
C	0.33	-	0.63
D	15.47	-	16.13
E	9.60	-	10.71
e	2.54 BSC		
F	2.34	-	2.84
G	6.48	-	6.90
L	12.24	-	13.72
L1	2.79	-	3.67
Q	2.52	-	2.96
Q1	3.10	-	3.50
ϕR	3.00	-	3.55

Note : Package body size, length and width do not include mold flash, protrusions and gate burrs.

DISCLAIMER:

The Products are not designed for use in hostile environments, including, without limitation, aircraft, nuclear power generation, medical appliances, and devices or systems in which malfunction of any Product can reasonably be expected to result in a personal injury. Seller's customers using or selling Seller's products for use in such applications do so at their own risk and agree to fully defend and indemnify Seller.

Magnachip reserves the right to change the specifications and circuitry without notice at any time. Magnachip does not consider responsibility for use of any circuitry other than circuitry entirely included in a Magnachip product. is  Magnachip a registered trademark of Magnachip Semiconductor Ltd.